

## Technical Guidelines for Primary Services

These guidelines are for property owners, developers, consultants, etc. (“**Customer**”) to use when coordinating a new or upgraded electrical service to a property (“**Service**”). They must be used in conjunction with the Conditions of Service for Enova Power Corp. (“**Enova**”), Enova’s Metering Specifications, Enova’s Service Connection Process for Commercial Services, the Ontario Building Code (“OBC”), the Ontario Electrical Safety Code (“OESC”) and all other applicable regulations.

### 1. General

- 1.1 Contact Enova’s Engineering Department prior to starting design to determine specific servicing requirements and service configuration type.
- 1.2 A site will generally require a primary service if the service size exceeds 400A at 347/600V or 600A at 120/208V, unless permitted otherwise by Enova.
- 1.3 Customer to follow Enova specified design timelines and document submission requirements as per the Enova’s “*Service Connection Process for Commercial Services*” document.
- 1.4 All materials, labour and trucking costs associated with the installation, relocation, removal, etc. of Enova-owned infrastructure for the purpose of the Service is 100% chargeable to the Customer, with the exception of transformation when supplied by Enova.
- 1.5 In most cases, Enova will provide and own transformer(s) and high voltage cables and the Customer will supply and install all required hydro civil work that may be required within the property. Refer to Appendix for installation details.
- 1.6 Enova may require multiple transformers and/or high voltage duct banks and/or switchgear on the property to provide a looped configuration of the Service if installation requires more than one transformer. This will minimize power outages and aid scheduled maintenance. Refer to Enova Conditions of Service for more details.

### 2. Typical Infrastructure Required

- 2.1 Underground high voltage duct bank(s), from a point of supply/supplies from Enova’s distribution system to the transformer(s) and/or switchgear unit(s);
- 2.2 Pad-mounted transformer(s) located on the Customer’s property complete with bollards, or electrical equipment vault room in the building containing transformers;

- 2.3 Pad-mounted or submersible switchgear unit(s) complete with bollards located on Customer's property, or electrical equipment vault room in the building containing switchgear unit(s);
- 2.4 An underground low voltage duct bank from the pad-mounted transformer(s) to the building(s);
- 2.5 Overhead infrastructure such as overhead primary conductors, load breaks, hydro poles, polemounted transformer(s), primary metering units and outdoor-rated enclosures for metering and SCADA equipment;
- 2.6 An electrical room in the building containing low voltage distribution, metering equipment and if required SCADA equipment.
- 2.7 Where the customer wishes to supply, install, and own their own transformer the following shall apply:
  - 2.7.1 Provide Enova with customer owned transformer specifications, installation details including grounding, and a complete protection coordination study to Enova for review and approval.
  - 2.7.2 Transformers 1500 kVA and larger shall have delta connected primary windings
  - 2.7.3 The Customer installed transformer must meet CSA Standard C802.1 or latest revision for energy efficiency.
  - 2.7.4 Typically, when the total customer owned transformation is greater than 3MVA and fed from Enova's 13.8kV system or 6MVA and fed from Enova's 27.6kV system, the customer will be required to install a high voltage circuit breaker with protections relays for phase and ground protections at the service entrance. Enova will provide upstream distribution system protection details to the customer to ensure proper distribution system coordination. The customer shall be responsible for carrying out a TCC study and propose settings that coordinate with Enova's upstream equipment. Enova must review and approve the customers TCC settings prior to service energization.

Enova will review large customer requests individually and provide connection details during review.

### **3. Easement Requirements**

- 3.1 Generally, Enova requires easement(s) for Enova owned high voltage infrastructure on private property. The easements are to be free of any structures, architectural features, underground utilities, tree roots, etc. The Customer shall provide easement(s) per the following unless a deviation or larger easement is required by Enova:
  - 3.1.1 A minimum of 3.0m wide easement over an underground high-voltage duct bank with the duct bank centered in the easement;

- 3.1.2 6.2m x 6.8m easement for the installation of an outdoor 3 phase pad-mounted transformer with the transformer foundation centered in the easement;
- 3.1.3 5.6m x 5.1m easement for the installation of an outdoor 1 phase pad-mounted transformer with the transformer foundation centered in the easement;
- 3.1.4 7.0m x 7.0m easement for the installation of an outdoor switchgear unit with the switch foundation centered in the easement;
- 3.1.5 Easement over entirety of electrical equipment vault rooms that contain Enova infrastructure;
- 3.1.6 Easement over guy anchors from Enova hydro poles.

#### **4. Clearance Requirements from Distribution Pole Lines**

- 4.1 A building, or any other structure, shall not be constructed within 5 meters (measured radially) of a high voltage conductor owned by Enova, or 6m (measured horizontally), from the center line of an overhead distribution system pole line owned by Enova (OBC 3.1.19 and OESC 75-708). Refer to Enova's standard 02-101A1 for details. Permanent structures within the Restricted Zone surrounding overhead lines are prohibited. When planning building construction, Customer should consider additional space required for construction (i.e. skyjacks, scaffolding, etc.), and maintenance (i.e. window cleaning).
- 4.2 An object (crane, similar hoisting device, backhoe, power shovel or other vehicle or equipment) shall not be brought closer than 3 meters to an energized overhead conductor owned by Enova (O.Reg 213/91 – Section 188).
- 4.3 Enova will not provide nor permit a third party contractor to cover-up and/or provide isolation of its energized overhead conductors that lie along a construction site (O.Reg 213/91 – Section 189).

#### **5. Space Requirements**

- 5.1 A minimum of 3 meters of clear space is required on the access side of a pad-mounted transformer, submersible switchgear, transformer room, or switchgear room. A minimum of 1 meter on the non-access side and/or switchgear unit is required free and clear of any obstructions for operational purposes. No curbs are permitted within 1m of a transformer or switchgear foundation. No concrete is permitted above a transformer or switchgear ground grid.
- 5.2 Pad mount transformers and switchgear owned by Enova shall be a minimum of 3m away from a building or any other customer owned structure including neighboring buildings.
- 5.3 A minimum of 1 meter in front of Enova-owned metering equipment with a minimum ceiling height of 2.1m is required for working space inside the

electrical room. Refer to Enova's Metering Specifications for additional requirements.

- 5.4 Where adequate land area cannot be provided for a pad-mounted transformer and where required by Enova, the Customer shall provide Enova with an electrical equipment vault room and/or switchgear room at grade level accessible directly from outside. There shall be no building overhang in front of the doors on the exterior of the building for Enova's truck mounted crane to lift the transformers and/or switchgear into the equipment vault unless a deviation has been allowed by Enova. Refer to Enova's Vault Room Standards in Appendices for requirements.
- 5.5 To access pad-mounted transformer(s) or electrical equipment vault room(s), the Customer shall provide Enova with a maintained road that is minimum 4.0m wide, with a minimum 15m turning radius, clear of any obstructions and capable of sustaining a maximum load of 25,000 kg to access the transformer(s), switchgear unit(s) or vault room(s). Any canopy or other parts of the building above the access driveway must be minimum 5.0 m above roadway. An 8.5m wide space is required for truck outriggers at the transformer location. Furthermore, an extra 2.5m is required between the transformer and the truck to accommodate minimum swing of the truck mounted crane
- 5.6 Any canopy or building overhang directly above an Enova owned transformer or switchgear must be a minimum of 11m above these structures. Where a building overhang encroaches on Enova's transformer or switchgear easements, seek direction from Enova. In general, no building overhangs are permitted with an encroachment into Enova's easement greater than 1m from the edge of the easement unless otherwise agreed to by Enova.

## **6. Access Requirements**

- 6.1 The Customer must provide or arrange free, safe and unobstructed access to any authorized representative of Enova for the purpose of Enova equipment maintenance, inspection, replacement etc.
- 6.2 The Customer shall be responsible for supplying Enova with a key for the premises if required to access Enova-owned equipment. Enova may request that the lock be keyed to Enova specifications.
- 6.3 Meter rooms, for multi-unit metering, shall be accessible to Enova via an outside lockable door at grade level unless otherwise agreed to by Enova. Refer to Enova's Metering Specification document for further details.

## 7. Installation Details

The Customer shall provide the required infrastructure in a location compliant with this document and approved by Enova, installed as per the following standards:

### 7.1 Transformer Installations:

- 7.1.1 Refer to Enova Standard 12-300A1 for the Brooklin Concrete Products Ltd. BCP-104SW transformer vault.
- 7.1.2 Refer to Enova Standard 12-300A2 for the Brooklin Concrete Products Ltd. BCP-104SW transformer vault grounding installation requirements.

### 7.2 Transformer Vault Room Installations:

- 7.2.1 Refer to Enova Standards 12-350A1 to 12-350A4 for installation requirements.

### 7.3 Switchgear Room Installations:

- 7.3.1 Refer to Enova Standards 12-370A1 and 12-370A2 for installation requirements.

### 7.4 Switchgear Vault Installations:

- 7.4.1 Contact Enova for installation drawings for submersible switchgear if required.

### 7.5 Duct Bank Installations:

- 7.5.1 Contact Enova for installation drawings for ductbank construction.

### 7.6 Metering Installations:

- 7.6.1 Refer to the latest edition of the Enova Metering Specifications and the site specific metering standards listed in the 'Offer to Connect' documentation for installation requirements.
- 7.6.2 If the site is fed from a customer owned distribution transformer the Customer must make provisions for bulk metering to accommodate a transformer discount meter.

**Appendices:**

- 02-101A1 – Clearances to Adjacent Structures 8.32kV - 27.6kV
- 12-300A1 – Custom BCP-104SW 3 Phase Transformer Vault
- 12-300A2 – Custom BCP-104SW Vault and Ground Grid Installation Details
- 12-350A1 – Transformer Vault Room Requirements
- 12-350A2 – Transformer Vault Room – Layout (Transformers up to 300kVA)
- 12-350A3 – Transformer Vault Room – Layout (Transformers greater than 300kVA)
- 12-350A4 – Transformer Vault Room – Secondary Transition Bus Details
- 12-370A1 – Vista Vault Room – Room Layout
- 12-370A2 – Vista Vault Room – Construction Details
- 12-400A1 – Typical Bollard Installation and Grounding Detail

**Note:**

Any standards provided by Enova are the sole property of Enova Power Corp. and are provided for information purposes only. The standards may be used in preparation of construction plans and specifications concerning Enova owned equipment only. No other use is authorized without prior written consent of Enova.

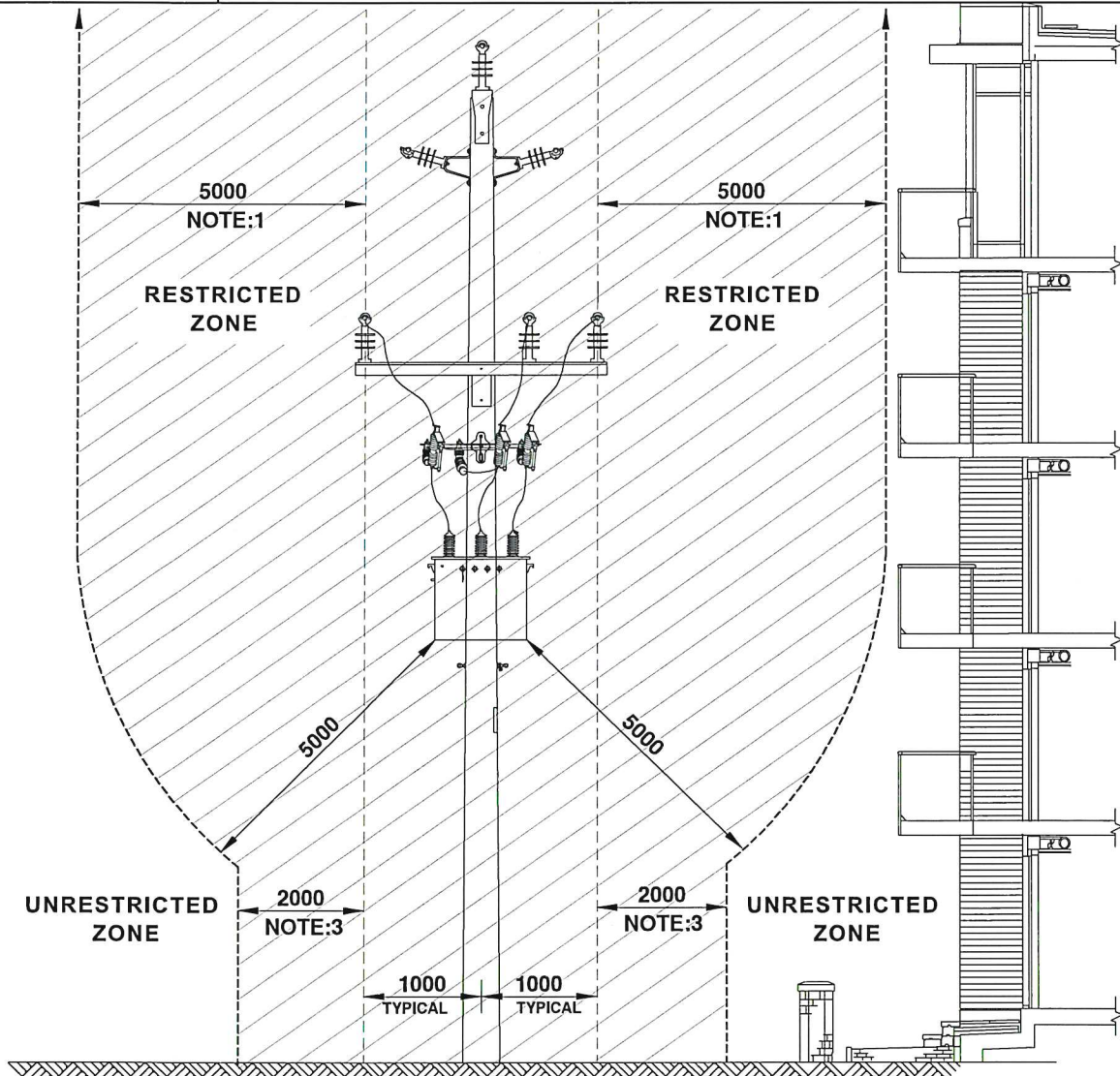

## NOTES:

1. NO PERMANENT BUILDING OR STRUCTURE SHALL BE PLACED WITHIN 5000mm MEASURED RADIALLY FROM ANY PRIMARY VOLTAGE (>750V) CONDUCTOR OR EQUIPMENT, MEASURED FROM THE CLOSEST PRIMARY CONDUCTOR (AT REST) TO THE CLOSEST POINT OF THE BUILDING OR STRUCTURE.
2. A MINIMUM HORIZONTAL SEPARATION OF 1500mm FROM THE BUILDING OR STRUCTURE TO THE SECONDARY CONDUCTOR (<750V) SHALL BE MAINTAINED, UNLESS THE SECONDARY CONDUCTORS CONNECT SUPPLY TO THE BUILDING'S ELECTRICAL SYSTEM.
3. NO PERMANENT BUILDING OR STRUCTURE SHALL BE PLACED OR CONSTRUCTED WITHIN 2000mm HORIZONTAL SEPARATION FROM THE OUTERMOST OVERHEAD PRIMARY CONDUCTOR (AT REST).
4. ZERO VOLTAGE SUPPORT WIRES (I.E. SPAN GUYS) MAY CROSS OVER THE CUSTOMER'S STRUCTURE AND SHALL MAINTAIN AT LEAST 2500mm VERTICAL CLEARANCE TO THE CLOSEST PART OVER THE BUILDING STRUCTURE.
5. CONTACT ENOVA TO DETERMINE SPECIFIC CLEARANCES APPLICABLE TO YOUR PROJECT.
6. CALCULATED CLEARANCES ARE BASED ON CONDUCTORS AT MAXIMUM SWING POSITION, CSA C22.3 NO. 1-20 TABLE 12, OBC 3.1.19, & OHSA.



\*\*ALL DIMENSIONS IN mm UNLESS OTHERWISE NOTED.

REV.	DESCRIPTION	DATE	INITIALS
1			
2			

**Certificate of Approval**  
 The installation work covered by this document meets the safety requirements of Section 4 of Regulation 22/04

Name: CARMEN FILIMON Date: SEPT 24, 2025  
 Signature: [Signature] P.ENG.



DATE:  
2025-01-31

SCALE:  
NTS

REV.  
3

DWG. NO.

12-300A1

TITLE: CUSTOM BCP104SW 3 PHASE TRANSFORMER VAULT

FRONT VIEW

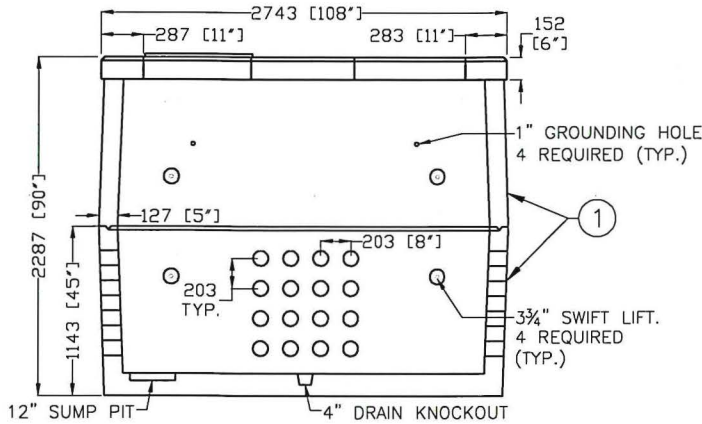

SIDE VIEW

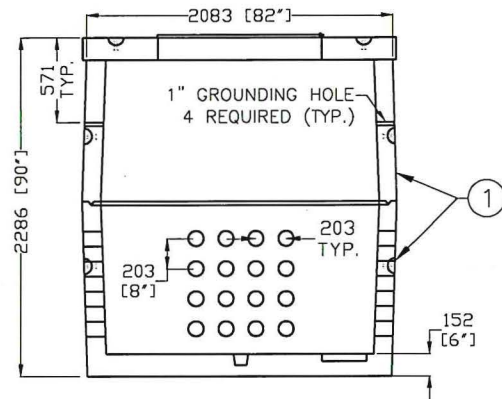

TOP VIEW

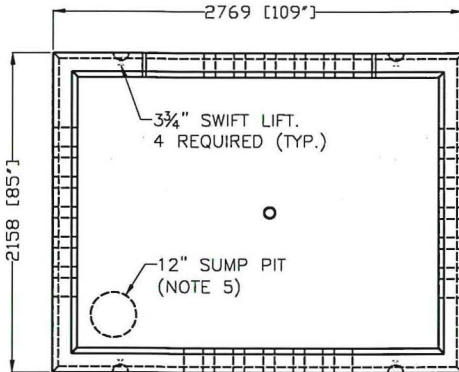

LID TOP VIEW

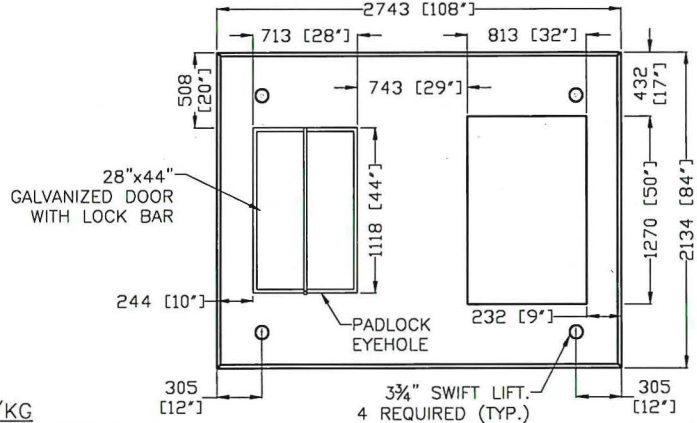

LID FRONT VIEW

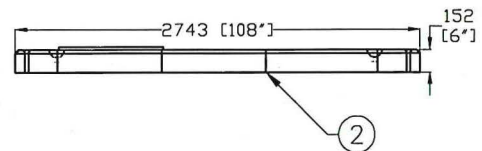

CONCRETE:

35MPa/5000PSI  
AIR ENTRAINMENT: 5-8%

REINFORCEMENT:

STEEL TO CSA CAN A23.1/A23.3.  
G30.18 Fy=400MPa

WEIGHT: LBS/KG

BOTTOM: 10,291/4,668  
MIDDLE: 6,237/2829  
TOP: 3,307/1,500  
TOTAL: 19,835/8,997

MAX EQUIPMENT WEIGHT:

29,244LBS/13,256KG

GENERAL NOTES:

- CABLE ENTRY OPENINGS-PVC SEALS FOR MAX. 4" I.D. DUCT.
  - DELIVERY IS MADE BY CRANE-EQUIPPED TRUCKS, EXCAVATION MUST BE READY, SAFE AND ACCESSIBLE FOR UNLOADING FROM THE REAR OF THE TRUCK.
  - MIN OVERHEAD CLEARANCE OF 18FT (5.5m) IS REQUIRED.
  - ALL UNITS MUST BE HANDLED WITH PROPER LIFTING EQUIPMENT. (I.E. SPREADER BAR).
  - SUMP PUMP PIT TO BE UNDER THE GALVANIZED DOOR SIDE.
  - LID TO BE ROTATED AND INSTALLED AS PER THE ENOVA DRAWING.
  - WATER PRESSURE WAS NOT CONSIDERED IN THE STRUCTURAL DESIGN. REPORT WATER TABLE DURING CONSTRUCTION.
  - PLACE BACKFILL SIMULTANEOUSLY AROUND THE VAULT TO AVOID UNBALANCE LATERAL EARTH PRESSURES.
  - BACKFILL SHOULD BE UNIFORMLY COMPACTED TO A MINIMUM OF 98% MATERIALS SPMD.
  - UNITS WILL BE SEALED WITH BUTYL TAPE AT THE JOINTS.
- \*\*ALL DIMENSIONS IN mm UNLESS OTHERWISE NOTED.

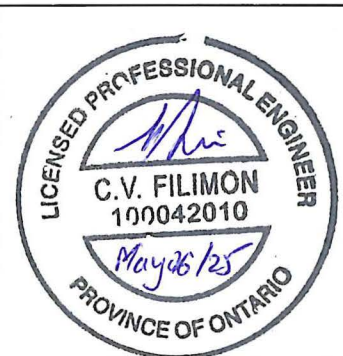

Certificate of Approval

The installation work covered by this document meets the safety requirements of Section 4 of Regulation 22/04

CARMEN FILIMON

MAY 06, 2025

Name

Date

Signature & Professional Designation

REV.	DESCRIPTION	DATE	INITIALS
1	UPDATED CUSTOM VAULT TO 3 PIECE BCP104SW.	2018-07-05	MS
2	UPDATED BRANDING	2023-05-26	AF
3	UPDATED VAULT DIMENSIONS & NOTES	2025-01-31	BM

**STANDARD**

**12-300A1**

**Material List**

Item	Quantity	Description	JDE Part #
1	1	2 piece Foundation, Concrete BCP104SW	38V 029 039
2	1	BCP104SW Concrete Top	

HIGHLIGHTED AREA IS TO BE KEPT FREE OF OBSTRUCTIONS

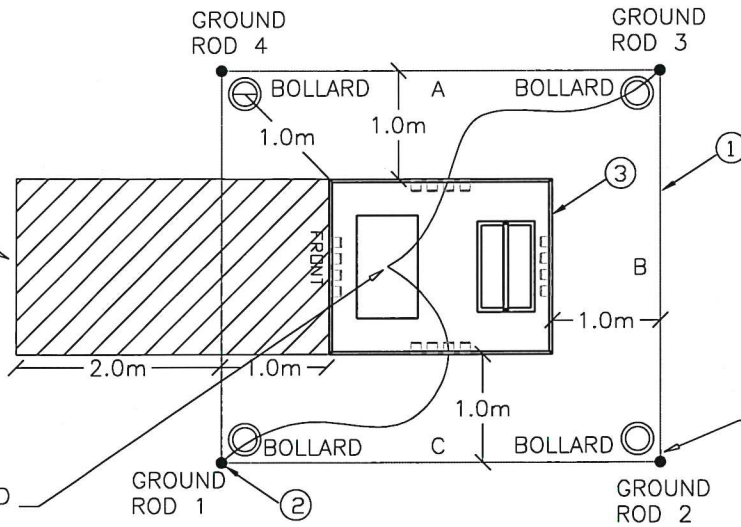

BOLLARDS TO BE GROUNDED AS PER STANDARD 12-400A1

ENOVA WILL CONNECT GROUND WIRES TO THE TRANSFORMER

BOLLARDS ARE TO BE INSTALLED ONLY IF THEY ARE REQUIRED TO PROTECT ENOVA EQUIPMENT FROM VEHICLE TRAFFIC. BOLLARD PLACEMENT SHOULD NOT INTERFERE WITH OPERATION, MAINTENANCE OR REPLACEMENT OF ENOVA EQUIPMENT.

\*\*ADDITIONAL BOLLARDS AT LOCATIONS A, B, C MAY BE REQUIRED FOR HIGH TRAFFIC AREAS\*\*

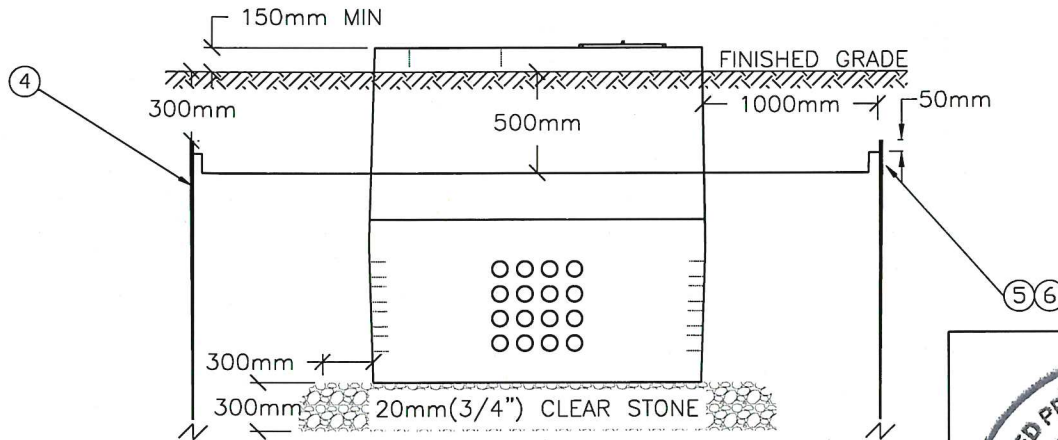

CUSTOMER TO INSTALL GROUNDING GRID PER ENOVA AND ESA STANDARDS:

1. FEED GROUNDING WIRE FROM INSIDE VAULT THROUGH LIFTING HOLE TO FASTEN TO GROUND ROD #1 WITH AMP TAP.
2. FASTEN GROUNDING WIRE TO GROUND RODS #2, #3 AND #4 WITH AMP TAPS MAINTAINING 500mm DEPTH FOR GROUNDING WIRE.
3. FASTEN GROUNDING WIRE TO GROUNDING WIRE AT GROUND ROD #1.
4. FEED GROUNDING WIRE FROM INSIDE VAULT THROUGH LIFTING HOLE TO FASTEN TO GROUND ROD #3 WITH AMP TAP.

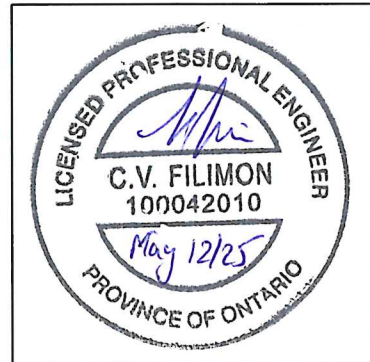

\*- DIMENSIONS ARE IN MILLIMETERS UNLESS OTHERWISE INDICATED

**Certificate of Approval**

The installation work covered by this document meets the safety requirements of Section 4 of Regulation 22/04

REV.	DESCRIPTION	DATE	INITIALS
①	UPDATED BRANDING.	2023/05/26	A.F.
②	UPDATED BRANDING.	2025/02/14	BM

CARMEN FILIMON  
Name  
MAY 12, 2025  
Date  
P. ENG.  
Signature & Professional Designation

**STANDARD****12-300A2**

Material List			
Item	Quantity	Description	JDE Part #
1	28m	Conductor 2/O Bare Strand Copper	38W 088 002
2	1	Connector, C Type 2/O - 2/O Copper	38G 067 027
3	1	Foundation Concrete BCP104SW	38V 029 039
4	5	Ground Rod, Copper Clad 3/4" x 10'	38G 067 030
5	5	Copper Tap Wedge Blue 350-2/0*	38C 070 044
6	5	Cartridge Blue Tap*	38C 070 001

\*CONSULT WITH ENOVA FOR ALTERNATE GROUND ROD CONNECTORS APPROVAL



DATE:  
2026-02-24

SCALE:  
NTS

REV.  
3

DWG. NO.

12-350A1

TITLE: TRANSFORMER VAULT ROOM - CONSTRUCTION DETAILS

THE CUSTOMER SHALL PROVIDE AT THEIR COST THE ITEMS LISTED BELOW IN COMPLIANCE WITH THE LATEST EDITIONS OF THE NATIONAL BUILDING CODE, ONTARIO BUILDING CODE (OBC), ONTARIO ELECTRICAL SAFETY CODE (OESC), NFPA80; ENOVA POWER CORP. (ENOVA) CONDITIONS OF SERVICE AND SITE SPECIFIC REQUIREMENTS LISTED IN ENOVA'S OFFER TO CONNECT (OTC).

1. ACCESSIBILITY:

- 1.1. ACCESSIBILITY MUST BE AT GRADE ON GROUND FLOOR WITH DIRECT OUTSIDE ACCESS AT ALL HOURS.
- 1.2. MUST BE ACCESSIBLE BY ENOVA LINE TRUCKS OVER A HARD SURFACE SUCH AS CONCRETE, ASPHALT, CRUSHED STONE OR OTHER ENOVA APPROVED MATERIAL.
- 1.3. THE VAULT ROOM SHALL NOT BE USED FOR STORAGE OR CONTAIN EQUIPMENT FOREIGN TO THE ELECTRICAL INSTALLATION.

2. VAULT WALLS, ROOF AND FLOORS:

- 2.1. WALLS, ROOF AND FLOORS TO BE REINFORCED CONCRETE WITH MINIMUM OF 0.15m THICKNESS.
- 2.2. CONCRETE FLOORS SHALL BE LIQUID TIGHT.
- 2.3. VAULT MUST BE THOROUGHLY CLEANED PRIOR TO INSTALLATION OF GROUNDING AND OTHER WIRING.
- 2.4. WALLS AND CEILING TO BE BARE CONCRETE OR PARGED FINISHED WITH A LIGHT GREY SURE-TRED RESILCRETE PAINT.
- 2.5. A COVERED OIL SUMP PIT SHALL BE PROVIDED CAPABLE OF HOLDING 800L OF OIL. SUMP PIT SHALL BE CONNECTED BY A 50mm DRAIN/TRAP TO A 100mm FLOOR DRAIN. SUMP PIT CAN BE REMOTE FROM TRANSFORMER ROOM.

3. INCOMING PRIMARY AND SECONDARY DUCTS:

- 3.1. THE PRIMARY AND SECONDARY SHALL BE LOCATED IN OPPOSITE DIAGONAL CORNERS OF THE VAULT ROOM WHERE PRACTICAL. **LAYOUT OF ROOM TO BE CONFIRMED WITH ENOVA PRIOR TO CONSTRUCTION.**
- 3.2. DUCTS TO BE INSTALLED WITH BELL END FITTINGS 0.15m ABOVE FINISHED FLOOR.
- 3.3. ROOMS SHALL BE COMPLETE WITH A SECONDARY TRANSITION BUS (SEE 12-350A4) OR, IF APPROVED BY ENOVA, CUSTOMER SECONDARY DUCTS/CABLE OPTION SHALL BE ALLOWED INSIDE THE VAULT ROOM. IF CUSTOMER SECONDARY CABLE IS APPROVED, CUSTOMER SHALL PROVIDE 11.0m OF SECONDARY CABLE PER RUN INSIDE VAULT ROOM WITH LUGS FOR ENOVA TO TERMINATE AND CONNECT TO TRANSFORMER.

4. VENTILATION:

- 4.1. OPENINGS TO BE FROM AN OUTDOOR AREA BY NATURAL VENTILATION WITHOUT THE USE OF DUCTS AND BE SIZED ACCORDING TO THE OBC SECTION 3.6.2.7 (0.002m<sup>2</sup>/kVA MINIMUM FOR THE COMBINED NET AREA OF INLET AND OUTLET OPENINGS)
- 4.2. HEIGHT TO WIDTH RATIO MUST NOT EXCEED 3:2.
- 4.3. THE BOTTOM OF THE AIR INTAKE VENT IS TO BE LOCATED AT A MINIMUM OF 0.45m AND A MAXIMUM OF 1.0m ABOVE OUTSIDE GRADE.
- 4.4. AIR EXHAUST VENT IS TO BE LOCATED AS CLOSE AS POSSIBLE TO VAULT CEILING.
- 4.5. IF THE AIR INTAKE AND THE AIR EXHAUST ARE LOCATED ON THE SAME WALL THEY SHALL BE SEPARATED IN DIAGONAL ALIGNMENT ON THE WALL.
- 4.6. OPENINGS SHALL BE EQUIPPED WITH LOUVRES AND A BIRD SCREEN WITH A MINIMUM 1/2" MESH AND HAVE 60mm SPACING. ORIENT LOUVRES TO DEFLECT AWAY ANY PRECIPITATION.
- 4.7. ALL MATERIALS TO BE 16 ga. GALVINIZED STEEL.

5. FIRE DOORS:

- 5.1. TWO CLASS 'A' 3 HOUR RATED FIRE DOORS WITH MIN. DIMENSIONS OF 1.0m x 3.0m PER DOOR.
- 5.2. DOORS COMPLETE WITH A 10" TAMPER PROOF PAD BOLT CAPABLE OF ACCEPTING A 5/16" ENOVA PADLOCK, A HASP AND TANG ARRANGEMENT, AND A HEAVY DUTY LOCKING PASSAGE KNOBSET (KNOBSET SUPPLIED BY ENOVA).
- 5.3. TO PREVENT REMOVAL OF DOORS EXTERNALLY, DOOR PINS ARE TO BE WELDED TO HINGE UNLESS DOOR PINS HAVE SET SCREW LOCKS AND HINGE PLATES THAT ARE CONCEALED OR WELDED.

6. FIRE PROTECTION AND ALARM:

- 6.1. 3 HOUR FIRE RATED CONSTRUCTION IS REQUIRED OF ALL VAULTS, INCLUDING AIRWAYS.
- 6.2. A CEILING MOUNTED SMOKE DETECTOR IS REQUIRED TO ACTUATE THE BUILDING FIRE ALARM SYSTEM IN CASE OF A FIRE.

7. GROUNDING:

- 7.1. CUSTOMER TO SUPPLY AND INSTALL FOUR 3/4" x 10' GROUND RODS IN THE FOUR CORNERS OF THE VAULT ROOM, PROTRUDING NO MORE THAN 300mm ABOVE GRADE.
- 7.2. CUSTOMER TO CONNECT DOORS AND LOUVRES TO THE GROUND LOOP USING #2/0 EXTRA FLEX STRANDED COPPER FOR THE DOORS AND MIN. #4 STRANDED COPPER FOR THE LOUVRES.
- 7.3. REMOTE GROUNDING GRIDS (IF APPLICABLE) TO BE APPROVED BY ESA, STAMPED BY A P.ENG AND SUBMITTED TO ENOVA FOR REVIEW.

8. ACCESSORIES:

- 8.1. SUPPLY/INSTALL TWO LIGHTS AND A 15A RECEPTACLE. **CONFIRM LOCATIONS WITH ENOVA PRIOR TO INSTALLATION.** LIGHTING SHALL PROVIDE 500 LUX AT FLOOR LEVEL.
- 8.2. SUPPLY AND INSTALL PULLING EYES CAPABLE OF SUPPORTING 2500KG IN THE CEILING AT A POINT 0.6m FROM VAULT WALL, CENTERED ON THE DOORWAY AND ROTATED TOWARDS PRIMARY DUCTS.

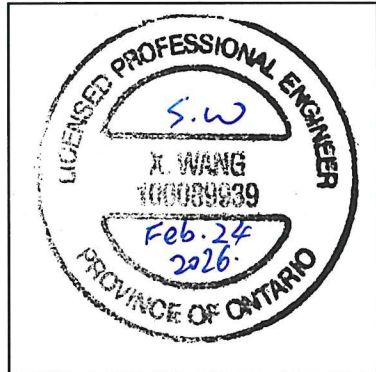

Certificate of Approval

The installation work covered by this document meets the safety requirements of Section 4 of Regulation 22/04

Shawn Wang Feb. 24, 2026

Date

P.Eng. Signature & Professional Designation

REV.	DESCRIPTION	DATE	INITIALS
2	UPDATED NOTES	2025/02/14	B.M.
3	ADDED 500 LUX LIGHTING LEVEL	2026/02/24	B.M.



DATE: 2025-02-14

SCALE: NTS

REV. 2

DWG. NO.

12-350A2

TITLE: TRANSFORMER VAULT ROOM - LAYOUT (TRANSFORMERS UP TO 300kVA)

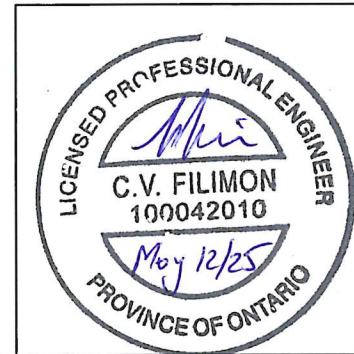
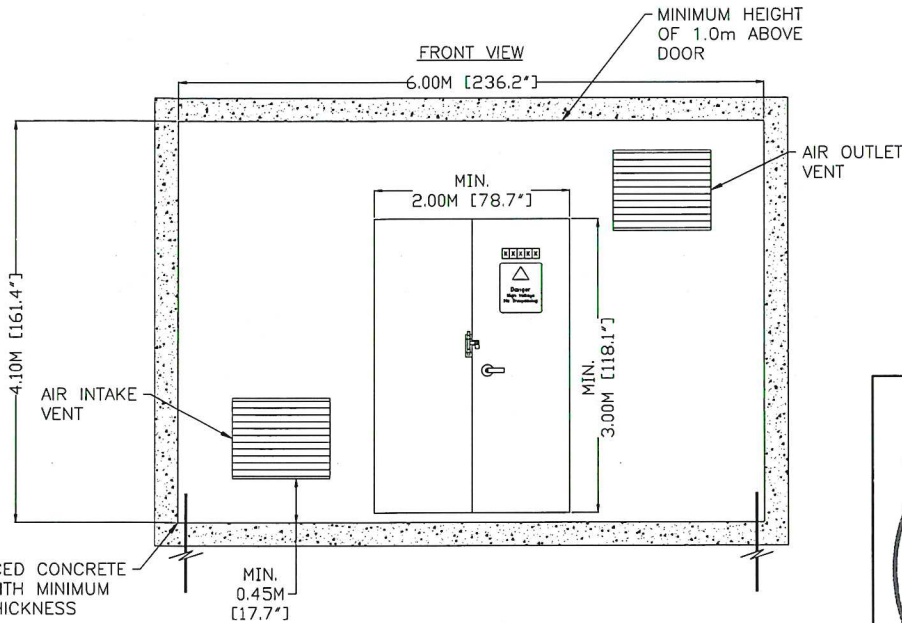
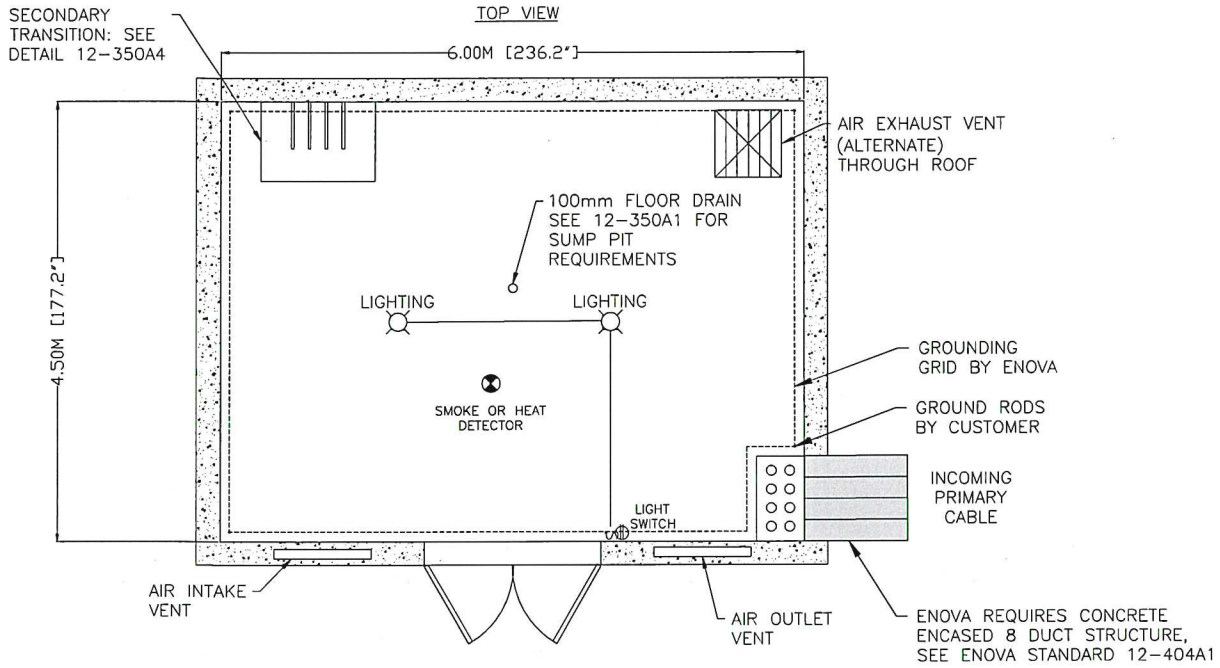

\*- DIMENSIONS ARE IN METERS UNLESS OTHERWISE INDICATED

**Certificate of Approval**

The installation work covered by this document meets the safety requirements of Section 4 of Regulation 22/04

REV.	DESCRIPTION	DATE	INITIALS
1	Updated branding.	2022/12/09	M.S.
2	ENOVA UPDATE.	2025/02/14	B.M.

CARMEN FILIMON  
Date MAY 12, 2025  
Signature & Professional Designation  
P.ENG.



DATE:  
2025-02-14

SCALE:  
NTS

REV.  
2

DWG. NO.  
12-350A3

TITLE: TRANSFORMER VAULT ROOM - LAYOUT (TRANSFORMERS GREATER THAN 300kVA)

SECONDARY TRANSITION:  
SEE DETAIL 12-350A4

TOP VIEW

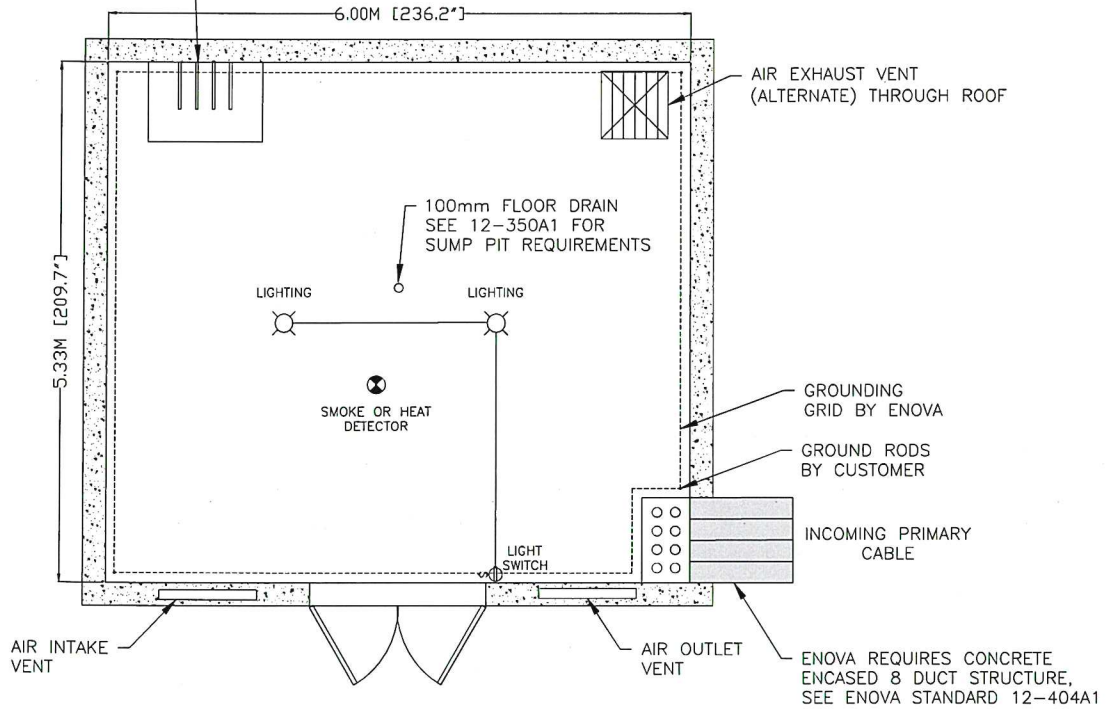

FRONT VIEW

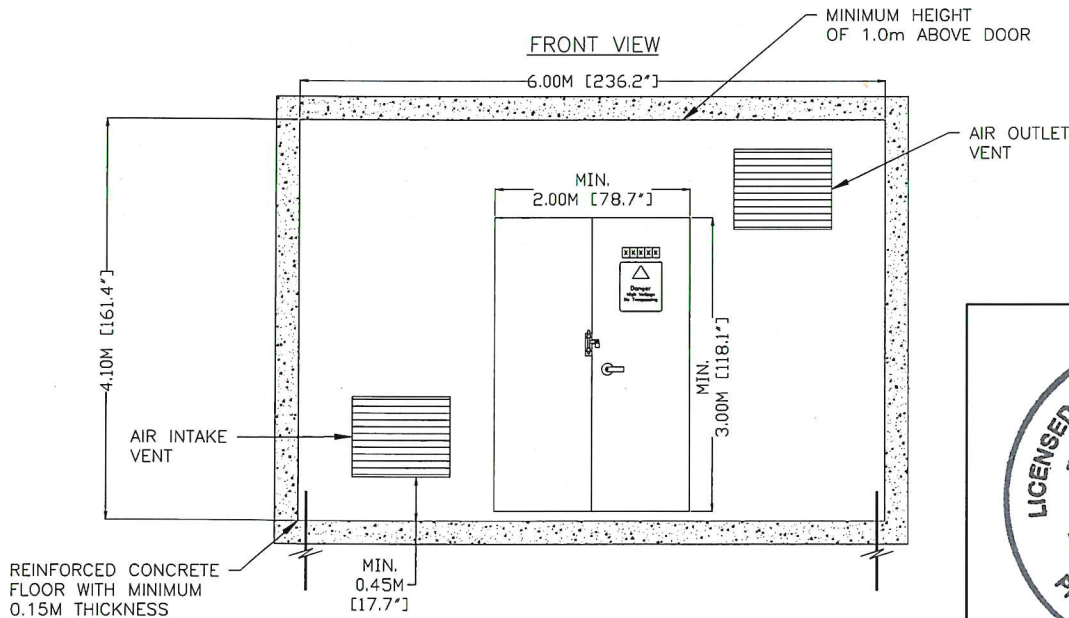

\*- DIMENSIONS ARE IN METERS UNLESS OTHERWISE INDICATED

REV.	DESCRIPTION	DATE	INITIALS
1	Updated branding.	2022/12/09	M.S.
2	ENOVA UPDATE.	2025/02/14	B.M.

**Certificate of Approval**  
The installation work covered by this document meets the safety requirements of Section 4 of Regulation 22/04

*Carmen Filimon* Date *MAY 12/2025*  
*M.F.* P.ENG.  
Signature & Professional Designation

## NOTES:

1. CUSTOMER TO SUPPLY AND INSTALL SECONDARY TRANSITION BUS AS PER THE ONTARIO ELECTRICAL SAFETY CODE AND THE ONTARIO BUILDING CODE REQUIREMENTS.
2. SECONDARY TRANSITION BUS SHALL BE AT A HEIGHT OF 2.0m FROM FINISHED VAULT ROOM FLOOR LEVEL. IF APPROVED BY ENOVA, TRANSITION BUS HEIGHT CAN BE REDUCED TO A MINIMUM OF 1.0m FROM FLOOR LEVEL. IF LOWER THAN 1.5m FROM FLOOR LEVEL, A GROUNDED METAL SHROUD IS REQUIRED.
3. SECONDARY TRANSITION COPPER BUS BAR SPADES TO BE SIZED AS PER ESA BY CUSTOMER WITH 8-14.3mm N.E.M.A. DRILLED HOLES.
4. MINIMUM CLEARANCE BETWEEN LIVE PARTS (METAL-TO-METAL BETWEEN BOLTS) SHALL BE NO LESS THAN 150mm.

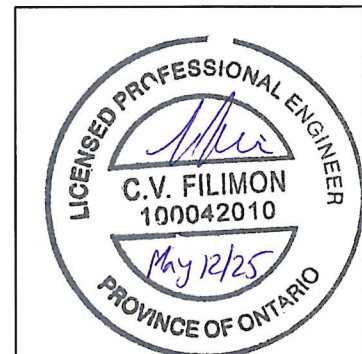
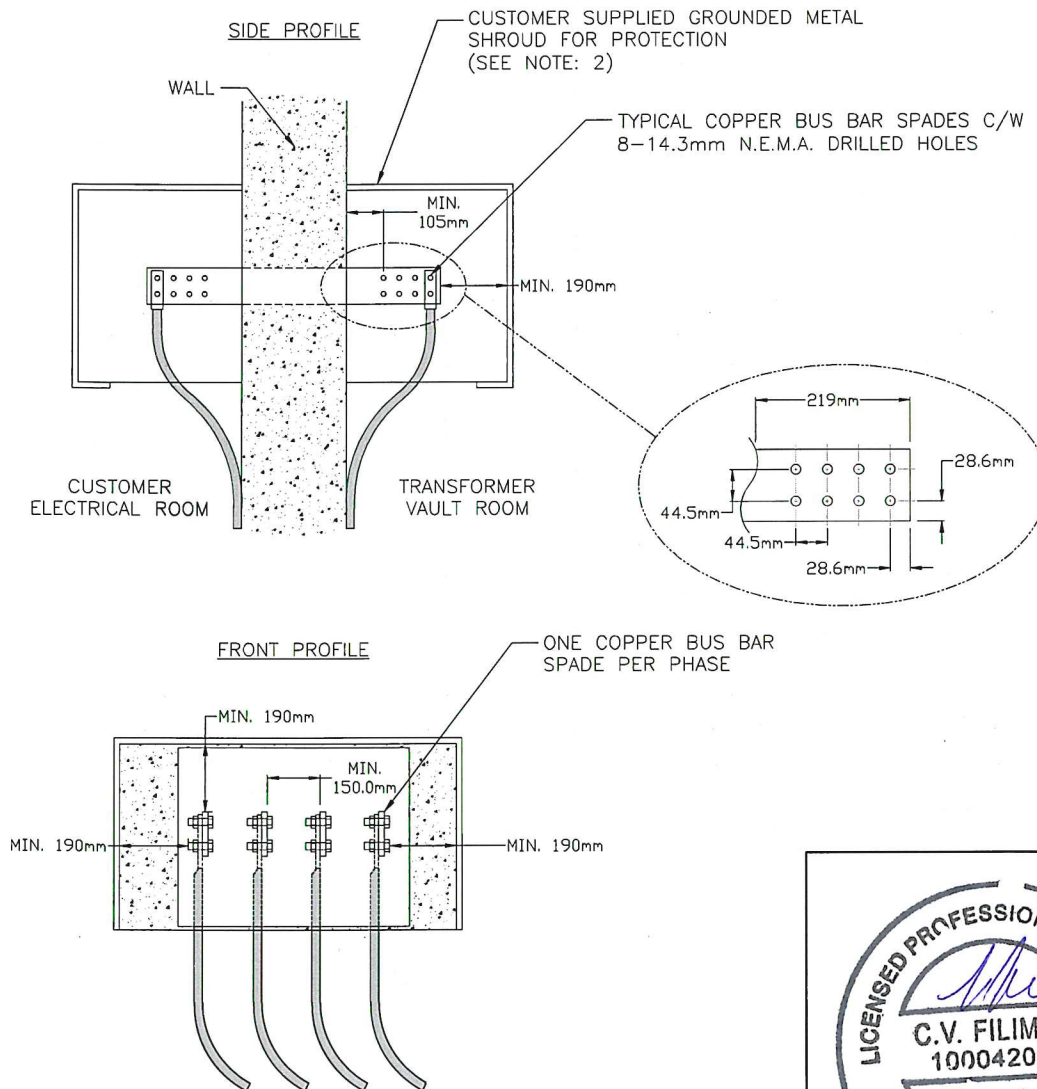

\*- DIMENSIONS ARE IN MILLIMETERS UNLESS OTHERWISE INDICATED

## Certificate of Approval

The installation work covered by this document meets the safety requirements of Section 4 of Regulation 22/04

REV.	DESCRIPTION	DATE	INITIALS
1	Updated branding.	2022/12/09	M.S.
2	ENOVA UPDATE.	2025/02/14	B.M.

CARMEN FILIMON MAY 12, 2025

Date

Signature & Professional Designation

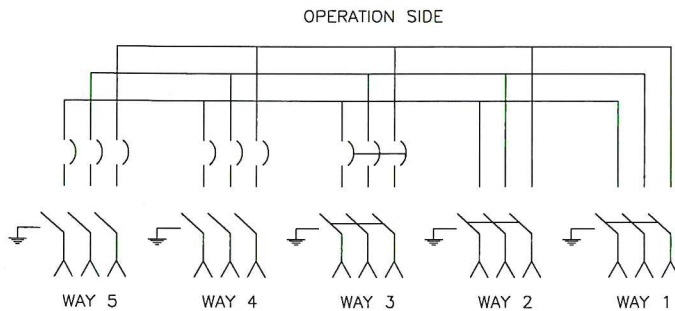
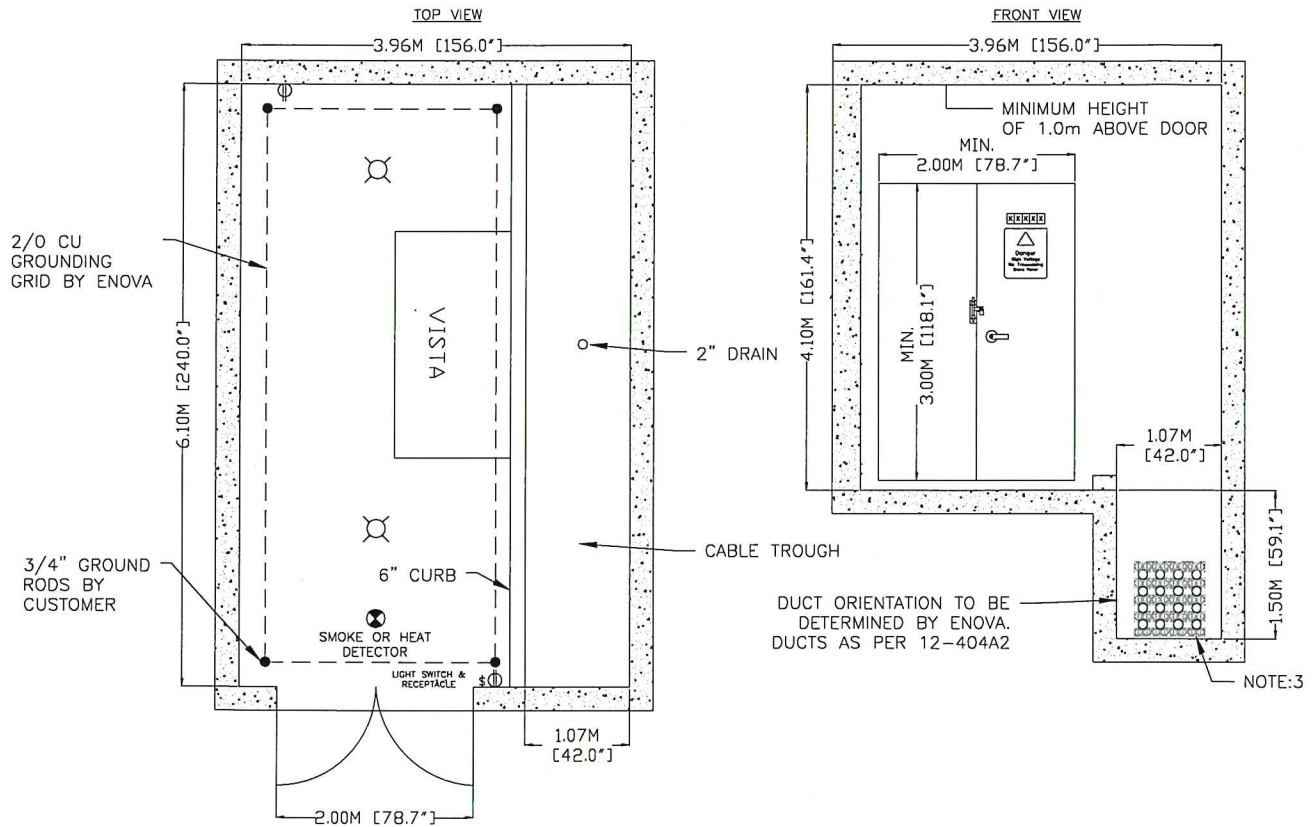

NOTES:

1. REFER TO 12-370A2 FOR CONSTRUCTION DETAIL REQUIREMENTS.
2. PLACE SWITCH AS SHOWN ON LAYOUT TO MAINTAIN MINIMUM WORKING SPACE.
3. CONFIRM TROUGH DEPTH WITH ENOVA PRIOR TO CONSTRUCTION. TROUGH DEPTH OF 1.5m IS TYPICAL.
4. TYPICAL ROOM CONFIGURATION SHOWN WITH CABLE PULLING TROUGH. CABLE TROUGH CAN BE OMITTED & ROOM SIZE REVISED WHILE MAINTAINING A ROOM SIZE OF 260 SQUARE FEET WITH ENOVA'S APPROVAL.
5. RACK CABLES AS PER 12-201A2.

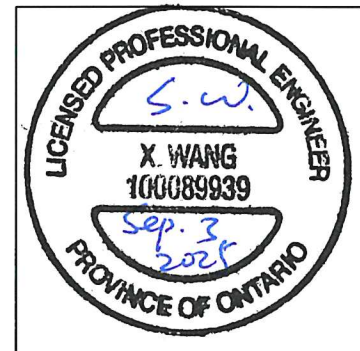

**Certificate of Approval**  
The installation work covered by this document meets the safety requirements of Section 4 of Regulation 22/04

*Shawn Wang* *Sep. 3 2025*  
Date  
*[Signature]* P. Eng.  
Signature & Professional Designation

REV.	DESCRIPTION	DATE	INITIALS



DATE:  
2026.02.24

SCALE:  
NTS

REV.  
1

DWG. NO.  
12-370A2

TITLE: VISTA VAULT ROOM - CONSTRUCTION DETAILS

THE CUSTOMER SHALL PROVIDE AT THEIR COST THE ITEMS LISTED BELOW IN COMPLIANCE WITH THE LATEST EDITIONS OF THE NATIONAL BUILDING CODE, ONTARIO BUILDING CODE (OBC), ONTARIO ELECTRICAL SAFETY CODE (OESC), NFPA80; ENOVA POWER CORP. (ENOVA) CONDITIONS OF SERVICE AND SITE SPECIFIC REQUIREMENTS LISTED IN ENOVA'S OFFER TO CONNECT (OTC).

1. ACCESSIBILITY:

- 1.1. ACCESSIBILITY MUST BE AT GRADE ON GROUND FLOOR WITH DIRECT OUTSIDE ACCESS AT ALL HOURS. WHERE UNDERGROUND PARKING EXISTS, THE VAULT ROOM SHALL LOCATED AT THE OUTSIDE EDGE OF THE UNDERGROUND PARKING. THE INCOMING DUCTS SHALL NOT PASS THROUGH THE PARKING STRUCTURE UNLESS A SITE SPECIFIC DEVIATION HAS BEEN APPROVED BY ENOVA.
- 1.2. MUST BE ACCESSIBLE BY ENOVA LINE TRUCKS OVER A HARD SURFACE SUCH AS CONCRETE, ASPHALT, CRUSHED STONE OR OTHER ENOVA APPROVED MATERIAL.
- 1.3. THE VAULT ROOM SHALL NOT BE USED FOR STORAGE OR CONTAIN EQUIPMENT FOREIGN TO THE ELECTRICAL INSTALLATION.

2. VAULT WALLS, ROOF AND FLOORS:

- 2.1. WALLS, ROOF AND FLOORS TO BE REINFORCED CONCRETE WITH MINIMUM OF 0.15m THICKNESS.
- 2.2. VAULT MUST BE THOROUGHLY CLEANED PRIOR TO INSTALLATION OF GROUNDING AND OTHER WIRING.
- 2.3. WALLS AND CEILING TO BE BARE CONCRETE OR PARGED FINISHED WITH A LIGHT GREY SURE-TRED RESILCRETE PAINT.
- 2.4. A 2" FLOOR DRAIN SHALL BE CONNECTED FROM THE CABLE TROUGH TO A STORM DRAIN.
- 2.5. THE CABLE TROUGH SHALL RUN THE LENGTH OF THE ROOM AT THE DEPTH SHOWN.

3. FIRE DOORS:

- 3.1. TWO CLASS 'A' 3 HOUR RATED FIRE DOORS WITH MIN. DIMENSIONS OF 1.0m x 3.0m PER DOOR.
- 3.2. DOORS COMPLETE WITH A 10" TAMPER PROOF PAD BOLT CAPABLE OF ACCEPTING A 5/16" ENOVA PADLOCK, A HASP AND TANG ARRANGEMENT, AND A HEAVY DUTY LOCKING PASSAGE KNOBSET (KNOBSET SUPPLIED BY ENOVA).
- 3.3. TO PREVENT REMOVAL OF DOORS EXTERNALLY, DOOR PINS ARE TO BE WELDED TO HINGE UNLESS DOOR PINS HAVE SET SCREW LOCKS AND HINGE PLATES THAT ARE CONCEALED OR WELDED.

4. FIRE PROTECTION AND ALARM:

- 4.1. 3 HOUR FIRE RATED CONSTRUCTION IS REQUIRED OF ALL VAULTS.
- 4.2. A CEILING MOUNTED SMOKE DETECTOR IS REQUIRED TO ACTUATE THE BUILDING FIRE ALARM SYSTEM IN CASE OF A FIRE.
- 4.3. VAULT ROOM SHALL NOT BE SPRINKLERED.

5. GROUNDING:

- 5.1. CUSTOMER TO SUPPLY AND INSTALL FOUR 3/4" x 10' GROUND RODS IN THE FOUR CORNERS OF THE VAULT ROOM, PROTRUDING NO MORE THAN 300mm ABOVE GRADE.
- 5.2. CUSTOMER TO CONNECT DOORS AND LOUVRES TO THE GROUND LOOP USING #2/0 EXTRA FLEX STRANDED COPPER FOR THE DOORS AND MIN. #4 STRANDED COPPER FOR THE LOUVRES.
- 5.3. REMOTE GROUNDING GRIDS (IF APPLICABLE) TO BE APPROVED BY ESA, STAMPED BY A P.ENG AND SUBMITTED TO ENOVA FOR REVIEW.
- 5.4. ENOVA TO INSTALL GROUND LOOP 300mm ABOVE FINISHED FLOOR. CONCENTRIC NEUTRAL'S AT CABLE TERMINATIONS SHALL BE TIED DIRECTLY TO THE VISTA MOUNTED GROUND BUS. THE GROUND BUS SHALL BE TIED TO THE GROUND LOOP AT BOTH ENDS OF THE GROUND BUS WITH 2/0 CU.

6. ACCESSORIES:

- 6.1. CUSTOMER TO SUPPLY/INSTALL TWO LIGHTS AND TWO 15A, 120V RECEPTACLES. **CONFIRM LOCATIONS WITH ENOVA PRIOR TO INSTALLATION.** LIGHTING SHALL PROVIDE 500 LUX AT FLOOR LEVEL.



**Certificate of Approval**  
 The installation work covered by this document meets the safety requirements of Section 4 of Regulation 22/04

*Shawn Wang*      *Feb. 29, 2026*  
 \_\_\_\_\_      \_\_\_\_\_  
 Signature & Professional Designation      Date

REV.	DESCRIPTION	DATE	INITIALS
Δ	ADDED 500 LUX LIGHTING LEVEL	2026.02.24	B.M.



DATE:  
2026.03.18

SCALE:  
NTS

REV.  
2

DWG. NO.

12-400A1

TITLE: TYPICAL BOLLARD INSTALLATION AND GROUNDING DETAIL

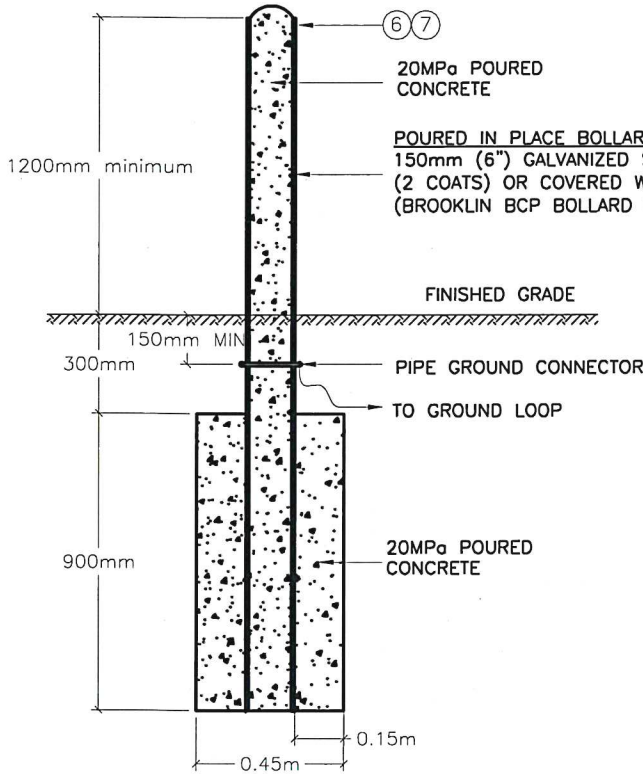

**POURED IN PLACE BOLLARD:**  
150mm (6") GALVANIZED STEEL PIPE PAINTED WITH RUST RESISTANT PAINT (2 COATS) OR COVERED WITH YELLOW PLASTIC COVERS (BROOKLIN BCP BOLLARD IS APPROVED ALTERNATIVE)

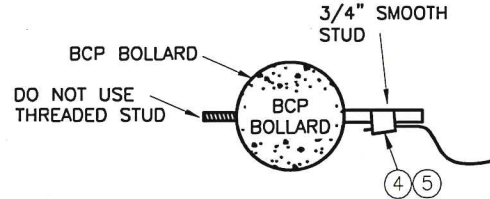

GROUND WIRE CONNECTION DETAIL FOR BROOKLIN BCP BOLLARD

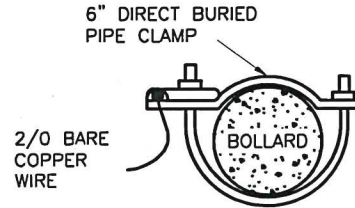

GROUND WIRE CONNECTION DETAIL FOR POURED IN PLACE BOLLARD

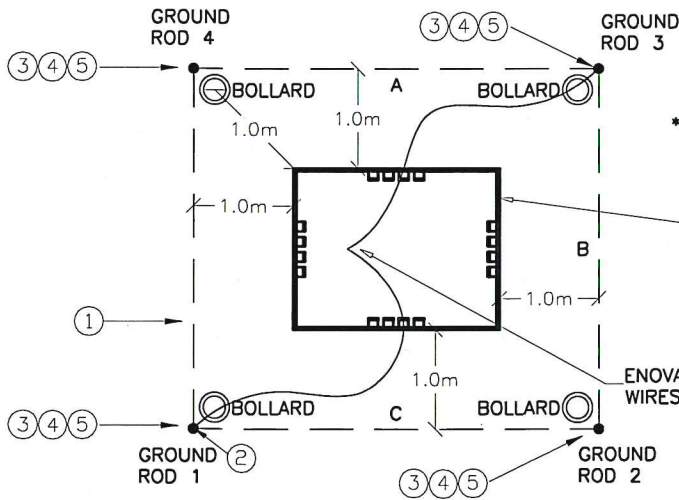

BOLLARDS SHALL BE CONNECTED TO THE GROUND GRID AS SHOWN BY THE ELECTRICAL CONTRACTOR.

\*-ALL DIMENSIONS ARE IN MILLIMETERS UNLESS OTHERWISE INDICATED

CONCRETE VAULT

ENOVA WILL CONNECT GROUND WIRES TO THE TRANSFORMER

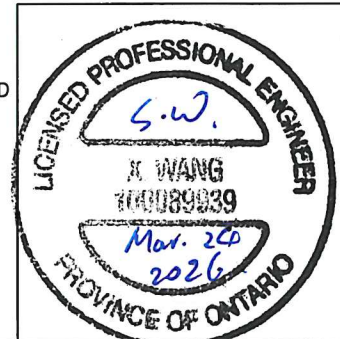

\*\*ADDITIONAL BOLLARDS AT LOCATIONS A, B, C MAY BE REQUIRED FOR HIGH TRAFFIC AREAS\*\*

BOLLARDS ARE TO BE INSTALLED ONLY IF THEY ARE REQUIRED TO PROTECT ENOVA EQUIPMENT FROM VEHICLE TRAFFIC. BOLLARD PLACEMENT SHOULD NOT INTERFERE WITH OPERATION, MAINTENANCE OR REPLACEMENT OF ENOVA EQUIPMENT.

**Certificate of Approval**  
The installation work covered by this document meets the safety requirements of Section 4 of Regulation 22/04

Shawn Wang Mar. 26, 2026  
Name Date

Signature & Professional Designation

REV.	DESCRIPTION	DATE	INITIALS
1	BOLLARD HEIGHT CHANGED FROM 900 TO 1200mm MIN.	FEB. 20-25	E.R.
2	ADDED BCP BOLLARD NOTES & DETAIL.	MAR. 18-26	B.D.

**STANDARD****12-400A1**

Material List			
Item	Quantity	Description	JDE Part #
1	28m	Conductor 2/0 bare Strand Copper	38W 088 002
2	4	Connector, C Type 2/0 - 2/0 Copper	38G 067 027
3	4	Ground Rod, Copper Clad 3/4"x 10ft	38G 067 030
4	4	Copper Tap Wedge Blue 350-2/0 (Note 1, 2)	38C 070 044
5	4	Cartridge Blue Tap (Note 1, 2)	38C 070 001
6		Yellow Plastic Covers supplied and installed by the Developer/Contractor	
7		Bollards and Grounding hardware supplied and installed by the Developer and or Contractor (Note 3)	Special Order

**NOTES:**

1. CONSULT WITH ENOVA FOR ALTERNATE GROUNDING CONNECTORS APPROVAL.
2. IF INSTALLING BCP BOLLARD, INCREASE ITEM QUANTITY TO 8.
3. BROOKLIN BCP BOLLARD OR POURED IN PLACE BOLLARD.
4. SEE DRAWING 12-300A2 FOR 3PH GROUND GRID INSTALLATION DETAILS.