



ENOVA POWER CORP.

# METERING SPECIFICATIONS

EFFECTIVE:

December 8, 2025

Revision 4

Approved by:

A handwritten signature in blue ink, appearing to read "Shaun Wang", is written over a horizontal line.

Shaun Wang, P.Eng.  
Manager of Distribution

<b>Certificate of Approval</b>	
The installation work covered by this document meets the safety requirements of Section 4 of Regulation 22/04	
A handwritten signature in blue ink, appearing to read "Shaun Wang", is written over a horizontal line.	Date
	Dec. 15, 2025
A handwritten signature in blue ink, appearing to read "Shaun Wang P. Eng.", is written over a horizontal line.	
Signature & Professional Designation	

See the Enova Power Corp. website for the latest revisions at [www.enovapower.com](http://www.enovapower.com). These specifications are for use only by Customers within the EPC service territory. This document does not replace notification and communication requirements for servicing. Enova Power Corp.'s liability to any person is limited to damages that arise directly out of the negligence or the willful misconduct of EPC.

## Document History

<b>Revision</b>	<b>Description</b>	<b>Date</b>	<b>Approvals</b>
0	Original Issue	June 2, 2008	Herbert Haller P.Eng VP, Engineering & Stations
1	Revision to Update Ganged Meter Base Part Number in Table 2	May 21, 2009	Erik Veneman, P.Eng. Manager of Distribution Engineering
2	ESA Certificate of Approval Added	June 2, 2011	Herbert Haller P.Eng VP, Engineering & Stations
3	Specification drawings Updated	May 1, 2021	Dorothy Moryc, P.Eng. VP, Engineering & Stations
4	Enova Standards Update	December 8, 2025	Shaun Wang, P.Eng. Manager of Distribution

TABLE OF CONTENTS

*Preface* ..... 4

**1. RESPONSIBILITIES** ..... **5**

1.1 ENOVA POWER CORP... ..... 6

1.2 THE CUSTOMER ..... 6

**2. GENERAL**..... **7**

2.1 ACCESS ..... 8

2.2 LOCATION ..... 9

*Outdoor:*..... 9

*Indoor:*..... 9

2.3 TECHNICAL REQUIREMENTS ..... 9

2.4 METER ROOMS..... 11

2.5 SERVICE IDENTIFICATION ..... 11

**3. EQUIPMENT REQUIREMENTS**..... **12**

3.1 SINGLE-PHASE SERVICES UP TO AND INCLUDING 200A ..... 13

3.2 SINGLE PHASE SERVICES ABOVE 200A..... 13

3.3 MULTI-UNIT SITES..... 13

3.4 THREE PHASE SERVICES ..... 14

3.5 CENTRAL METERING ..... 15

3.6 PRIMARY METERING..... 16

3.7 INTERVAL METERING..... 16

3.8 GENERATION METERING ..... 17

*Net Metering* ..... 17

*IESO Contracted Generators Micro FIT and FIT* ..... 17

*Load Displacement Generators:* ..... 17

*Emergency Backup Generators*..... 17

3.9 PULSE OUTPUTS ..... 18

3.10 FIRE EQUIPMENT CONNECTION..... 18

**4. APPENDICIES**..... **19**

**APPENDIX ‘A’** ..... **20**

**METERING STANDARDS DRAWINGS** ..... **20**

**APPENDIX ‘B’** ..... **22**

**EPC APPROVED METER BASES**..... **23**

**APPENDIX ‘C’** ..... **23**

**EPC APPROVED COMBINATION TRANSFER SWITCH METER BASES & PLUG-IN TRANSFER DEVICES** ..... **24**

**APPENDIX ‘D’** ..... **24**

**METERING PULSE OUTPUT(S) ACCESS AGREEMENT**..... **24**

### **Preface**

This specification prescribes the requirements for Enova Power Corp. (EPC), metering equipment installation. It is the Customer's and their Electrician/Contractor's responsibility to familiarize themselves with these specifications.

EPC reserves the right to refuse to energize any part of the electrical plant that does not conform to these specifications. EPC assumes no responsibility whatsoever for the cost of repairs, or delays in energizing the system incurred as a result of disregarding these specifications.

The latest edition of the Ontario Electrical Safety Code shall apply unless otherwise stated in these specifications. The Customer and its agents are to familiarize themselves with, and abide by, all relevant Provincial Statutes and Municipal By-Laws. Such relevant regulations include in part, the Occupational Health and Safety Act and Regulations for Construction Projects. Also applicable are The Region of Waterloo, The City of Kitchener, The City of Waterloo, The Township of Wilmot, The Township of Woolwich and The Township of Wellesley's By-Laws.

EPC is regulated by the Ontario Energy Board (OEB) and complies with Section 3 of the Distribution System Code, which outlines the requirements for connections and expansions.

Section 1 of these Metering Specifications provides general EPC and Customer responsibilities. Sections 2 and 3 provide technical requirements. Also included are drawings and tables providing additional detailed information. Additional metering requirements are listed in the OEB's Distribution System Code. Metered Market Participants in the Independent Electricity System Operator (IESO) administered wholesale market must meet or exceed all IESO metering requirements.

In all cases, the Customer shall consult with EPC prior to the start of work to determine specific metering requirements. Meters shall not be installed unless all applicable requirements have been met.

# **1. RESPONSIBILITIES**

### 1.1 **Enova Power Corp.**

- 1.1.1 EPC shall supply and maintain revenue meters, instrument transformers (IT's), interconnecting wiring, ancillary devices, secondary wiring, seals, and other related equipment for revenue metering in a timely manner and in compliance with applicable legislation, EPC's Metering Specifications, and EPC's Conditions of Service.

### 1.2 **The Customer**

- 1.2.1 The Customer shall comply with these specifications for each type of electrical service listed, EPC's Conditions of Service and all applicable legislation.
- 1.2.2 Detailed power riser diagrams and drawings showing the metering provision and arrangement for all commercial services shall be submitted to EPC for approval before construction begins.
- 1.2.3 Prior to issuing a Service Order to have the metering equipment installed and the service energized, the Customer must contact EPC's Customer Service Department and open a new account.

## **2. GENERAL**

### 2.1 Access

- 2.1.1 EPC shall have access to Customer property to install, read, and maintain its metering equipment, in accordance with these requirements and Section 40 of the Electricity Act.
- 2.1.2 The Customer must provide or arrange free, safe and unobstructed access during regular business hours to any authorized representative of EPC for the purpose of meter reading, meter changing, or meter inspection. Where premises are closed during EPC 's normal business hours, the Customer must, on reasonable notice, arrange such access at a mutually convenient time.
- 2.1.3 The Customer shall be responsible for supplying a key to EPC. EPC may request that the lock be keyed to EPC specifications. In specific instances and at the sole discretion of EPC, the requirement for an outside door may be waived.
- 2.1.4 If the metering equipment is located on a mezzanine, there must be a proper stairway which is compliant with applicable building and safety regulations, including a handrail that leads to the location.
- 2.1.5 No person, except those authorized by EPC, may remove, connect, or otherwise interfere with EPC 's meters, wires, ancillary equipment or seals. The Customer shall be responsible for the care and safekeeping of EPC meters, wires and ancillary equipment on the Customer's premises. For deliberate damage or negligence of EPC equipment, other than by ordinary wear and tear, wind or lightning, the Customer shall be liable to pay to EPC the value of such equipment, or at the option of EPC, the cost of repairing the same.
- 2.1.6 An adequate working space in front of equipment, with a radius not less than 1m (39") and minimum ceiling height of 2.1m (83") for the full width of the installation shall be maintained at all times. The floor surface shall be solid and flat with no more than five (5°) degree slope. This space shall not be used for storage, etc. Noticeable, repetitive obstruction of this working space can be remedied by EPC notifying the Fire Department and Electrical Safety Authority.
- 2.1.7 An unobstructed working space in front of equipment shall be maintained, free from or protected against the adverse effects of moving machinery, vibration, dust, moisture or fumes.
- 2.1.8 Metering equipment shall not be located in a space that could become a confined space.
- 2.1.9 Any compartments, cabinets, boxes, sockets, or other workspace provided by the Customer for the installation of EPC 's metering equipment shall be for the exclusive use of EPC. No equipment, other than that provided and installed by EPC, may be installed in any part of the EPC metering workspace.
- 2.1.10 Where excessive vibration may affect or damage EPC metering equipment, adequate shock absorber mounting suitable to EPC shall be provided and installed by the Customer. The Customer or their contractor shall contact EPC when there is the possibility that such conditions may occur.
- 2.1.11 Where there is the possibility of danger to EPC employees or damage to equipment from moving machinery, dust, fumes, moisture, vandalism etc., protective arrangements satisfactory to EPC and the Electrical Safety Authority shall be made.
- 2.1.12 All site installations shall be considered as "Safe Work Site Areas". A safe work site area shall be determined when the meter installer is on location. If a work site is deemed unsafe or there are safety concerns by the installer, the installation of the meter shall not proceed until appropriate remedies are put in place.
- 2.1.13 If, in the sole opinion of EPC, building additions, alterations, fencing, tree growth or other obstruction, etc. render the meter inaccessible for reading and/or servicing, the meter shall be

relocated to an EPC approved location at the Customer's expense. Where such a condition exists, the Customer shall be granted 30 days to relocate the meter or ensure suitable access.

### 2.2 Location

- 2.2.1 All meters and meter cabinets shall be mounted level in the horizontal and vertical planes.
- 2.2.2 Meters are to be mounted at a height of 1.5m (5'-0")  $\pm$  150mm (6") when measured from finished grade to the center of the meter face/glass.

#### Outdoor:

- 2.2.3 Meter bases shall be mounted on the exterior of the building within 3.0m (10') of the front corner of the building unless a variance has been approved by Enova. The front of the building is that side which is the closest point of supply as determined by EPC's Engineering Department.
- 2.2.4 No part of the meter base is permitted to be above central air conditioners, window wells or any obstacles that prevent access to the meter. The meter shall be located on the street side of fences or other structures that would prohibit access to the meter.
- 2.2.5 No part of the meter base is permitted within 1.0m (118") of a gas meter.
- 2.2.6 A temporary finished grade may be permitted only if the meter installer agrees the grade is acceptable and the surface area is safe to work on. This temporary grade condition must still meet the terms of item 2.2.1 and 2.2.2. This is only a temporary condition until final grading can be completed. The permanent finished grade should not be altered in any way after the meter has been installed.
- 2.2.7 All metering cabinets and enclosures that are located outdoors shall be stainless steel and have a minimum NEMA 3R outdoor rating complete with a 200W heater.

In specific instances and at the sole discretion of EPC, a separate meter base enclosure may be requested to protect against vandalism or harsh environmental conditions.

#### Indoor:

- 2.2.8 If a metering center is used, the minimum height allowed for the bottom row of meters is 0.6m (24") and the maximum height allowed for the top row of meters is 1.82m (6'0")  $\pm$  150mm (6") as shown in drawing "MS-20B". Both dimensions are measured from finished floor elevation to the center of the meter face/glass.
- 2.2.9 Metering cabinets, if required, shall be mounted at 1.82m (6')  $\pm$  50mm (2") with the exception of a 1200mm x 1200mm x 300mm (48" x 48" x 12") meter cabinet which shall be mounted at 1.98m (6'6")  $\pm$  50mm (2") from the finished floor elevation to the top of the metering cabinet. All cabinets to be mounted with the right door opening first.
- 2.2.10 The Customer's main switch shall be installed so that the top of the switch is 1.82m (6') or less from the finished floor elevation. The Customer's main switch shall permit the sealing and padlocking of the handle in the "open" position and the cover or door in the "closed" position.

### 2.3 Technical Requirements

- 2.3.1 Metering will typically be installed on the low voltage side of the EPC or Customer owned transformer (secondary metering). Primary metering may be provided at the discretion of EPC.

For primary metering details, refer to Section 3.6.

- 2.3.2 To preserve the integrity and accuracy of EPC's metering systems, no devices other than those required for EPC's purposes shall be permitted to be connected to the metering circuits. Any metering or load control equipment required by the Customer must be connected to the Customer's own current and voltage transformers, which must be installed on the load side of EPC's metering equipment. Any secondary arresters, power factor correction capacitors, ground fault indicator lights or other Customer equipment must also be connected on the load side of EPC's metering equipment. All Customer connections shall be made to the load side of EPC's metering.
- 2.3.3 Customer owned metering or load control equipment cannot be installed in the same metering cabinet or metering switchgear cell, as those of EPC.
- 2.3.4 The Customer is required to supply, install and maintain an ESA compliant and EPC approved meter base for the use of EPC's self-contained socket meters. For a list of approved meter bases, refer to Appendix B.
- 2.3.5 All meter bases must be equipped with tunnel type lugs on the line side for termination of EPC's copper or aluminum conductors and be equipped with a dielectric cover and security ring.
- 2.3.6 Any conduits for the exclusive use of EPC metering circuits shall have no more than three 90° bends. No fittings with removable covers are permitted. The Customer or Contractor shall install a nylon or a poly rope pull line in the conduit with an excess of 200mm (8") loop left at each end.
- 2.3.7 Meter bases for use on Commercial/Industrial installations shall be installed on the load side of the Customer's main switch and located indoors. The Customer is required to supply and install a 5-jaw or 7-jaw, CSA approved meter socket. Where a neutral connection to the meter socket is required, it shall be not less than #12 AWG copper or equivalent and made directly to the neutral bus.
- 2.3.8 In specific instances and at the sole discretion of EPC, the main disconnect and metering for Commercial/Industrial installations may be approved to be located outdoors. If outdoor metering is approved, the meter cabinet must be constructed of stainless steel and have a minimum NEMA 3R outdoor enclosure rating and a 200W heater.
- 2.3.9 Barriers are required in each section of switchgear or service entrance equipment between metered cells and all adjacent cells.
- 2.3.10 Side-hinged doors shall be installed over all live electrical equipment where EPC personnel may be required to work (i.e., line splitters, un-metered sections of switchgear, breakers, switches, metering compartments, meter cabinets and enclosures). These hinged doors shall have metal latch with provision for sealing and padlocking. Where bolts are used, they shall be of the captive knurled type. All outer-hinged doors shall open no less than 135°. All inner-hinged doors shall open to a full 90°.
- 2.3.11 Typically, each detached, semi-detached or row housing unit (freehold or condominium) will be separately metered by a meter that is located outside. For condominium row housing, all meter bases for each block must be installed using EPC approved meter bases located on one end of each block (as per the design drawing). The Customer shall be responsible for the extension of the unit services from the meter to the individual units. The individual units must be numbered and identified in accordance with Section 2.5 and drawing "MS-1". Refer to Section 3.3 for further details on multi-unit metering.
- 2.3.12 Meters for new or upgraded residential services shall be mounted outdoors on a meter base approved by EPC. See Appendix B.

- 2.3.13 When a residential Customer is upgrading their service capacity, and the meter is inside, it must be moved outside to an EPC approved location at the Customer's expense.

### 2.4 Meter Rooms

- 2.4.1 Meter rooms for multi-unit commercial buildings shall be located on the main floor of the building and accessible to EPC via an outside lockable door at grade level unless otherwise agreed to by EPC. The minimum door dimensions shall be 2.0m x 0.81m (6'8" x 2'8"). The Customer shall be responsible for supplying a key to EPC. EPC may request that the lock be keyed to EPC specifications.
- 2.4.2 Lighting levels of at least 500 lux shall be maintained.
- 2.4.3 No water, gas, sewer, or other pipes, communications wire or equipment shall be permitted to encroach on the safe working space requirements, as viewed by EPC, of the metering equipment. Where a meter room is provided, no items near the room can present a hazard to EPC employees.
- 2.4.4 In specific instances and at the sole discretion of EPC, the requirement for an outside door may be waived (i.e., a high-rise apartment building where meter rooms may be required to be located on more than one floor).

### 2.5 Service Identification

- 2.5.1 Customers shall permanently and legibly identify all metered services with respect to unit number and/or civic address. The units, meter bases and main panel disconnect switches must have permanent unit numbers installed prior to the installation of any metering apparatus according to drawing "MS- 1".
- 2.5.2 The Customer must inform EPC in writing if changes are made to unit numbering and shall be liable to pay EPC any costs incurred as a result of unit re-numbering.

### **3. EQUIPMENT REQUIREMENTS**

### 3.1 Single-Phase Services Up to and Including 200A

- 3.1.1 For metering locations and servicing details, refer to drawing "MS-10A".
- 3.1.2 Each detached, semi-detached or linear row-housing unit shall be separately metered.

### 3.2 Single Phase Services Above 200A

#### 3.2.1 225A to 400A single phase service requirements:

- a) Use of an EPC approved transformer-rated combination meter base. Refer to drawing "MS-10D" for installation details and Appendix B for approved meter bases.
- b) Customer to supply and install combination meter base enclosure outside complete with lugs for conductor terminations on both sides of the EPC supplied Current Transformer (CT). Customer shall be responsible for load side conductor termination and line side conductor termination (if Customer owned conductor) inside the meter base.
- c) The 5-jaw meter base must be equipped with an automatic bypass for the current circuit on the left side, with the 5th-jaw located at the 9 o'clock position and equipped with a stainless-steel security ring.

#### 3.2.2 225A to 600A single phase service requirements:

- a) See section 3.5 for central metered service (CMS) services.
- b) For indoor services Customer shall supply and install 0.9m x 0.9m x 0.3m (36"x36"x12") metering cabinet and EPC approved 5-jaw meter base. Refer to drawings "MS-2 and MS-10F" for installation details and Appendix B for approved meter bases. If a customer requires a greater service size than 600 amperes, single-phase, they will be required to convert to a three-phase service, at their expense.

### 3.3 Multi-Unit Sites

- 3.3.1 The Customer or a representative must be present at the time of the meter installation and assist in the verification of each unit. The Metering Department at EPC needs to be notified at least 5 working days in advance to arrange a day and time (during normal working hours) to meet on site.
- 3.3.2 The Customer and/or electrician shall provide EPC with the following, prior to the service being energized:
  - a) All keys required to gain access to the electrical and metering rooms
  - b) A copy of the building layout, indicating the municipal address and permanent unit numbers, for each floor if applicable, duly signed by the electrician or developer as correct.
  - c) A copy of the meter panel layout, indicating the correct corresponding permanent unit numbers, for each floor if applicable, duly signed by the electrician or developer as correct.
- 3.3.3 The units, doors, meter bases and main disconnect switches must have permanent unit numbers installed prior to the installation of any metering apparatus according to drawing "MS-1".
- 3.3.4 Examples of the equipment layout for multi-unit metering are shown in drawings "MS-10A, MS-10B, MS-20A, MS-20B, MS-30B and MS-30C."

- 3.3.5 All new multi-tenant buildings shall be individually metered by EPC or a licensed Sub-Metering provider.
- 3.3.6 For existing apartment buildings, the owner may choose to switch from bulk metering to EPC individual metering.
- 3.3.7 For row housing all meter bases for each block must be as per the design drawing. The owner is responsible for the extension of the unit services from the meter base to the individual units.
- 3.3.8 For shopping plaza and industrial mall metering, EPC or a licensed Sub-Metering provider shall individually meter each separate store, shop, or industrial unit located in a shopping plaza.

### 3.4 Three Phase Services

#### 3.4.1 Services without switchgear:

For all three-phase services 225-800 amperes, without switchgear.

- a) Refer to drawings "MS-2 and MS-30D," and for equipment requirements and layout details.
- b) The Customer shall supply and install a 0.9m x 0.9m x 0.3m (36" x 36" x 12") or 1.2m x 1.2m x 0.3m (48" x 48" x 12") metering cabinet (stainless steel NEMA 3R if outdoors) and an EPC approved 13 jaw meter base in accordance with the applicable metering drawings listed in 3.4.1(a). See Appendix B for approved 13 Jaw meter bases.
- c) Additional notes for services requiring metering cabinets:
  - i. The Customer shall supply and install bonding as shown in drawing "MS-2".
  - ii. When bar type CT's are used, the Customer's Electrician shall supply an isolated neutral block in the cabinet.
  - iii. The Customer or Contractor shall contact EPC's Metering Department to arrange a time for back plate drop-off during regular business hours. A minimum of 10 working days is required for EPC staff to build and install the metering equipment. Upon completion, EPC's Metering Department shall notify the Customer or Contractor and arrange a date and time (during normal working hours) to receive the prepared back plate. It is the Customer's or a Contractor's responsibility to install the back plate.
  - iv. Within 10 working days of meter back plate installation, the Customer shall supply and install a grounded 120VAC duplex receptacle fed from a dedicated 15A single-pole breaker and routed via EMT conduit. Wiring to receptacle to be kept to minimum length possible.
- d) Interval meters shall be installed for all new or upgraded services where the monthly average peak demand over a calendar year could exceed 50 kW or greater. Refer to Section 3.7.

#### 3.4.2 Services with switchgear:

For three-phase services greater than or equal to 225 amperes with switchgear:

- a) Refer to drawings "MS-20B, MS-30A, MS-30B and MS-30C" for equipment requirements and layout details

- b) The Customer shall provide EPC a set of original switchgear drawings from the manufacturer. Any discrepancies between the submitted drawings and the equipment on-site shall require re-submittal of new drawings. EPC will not provide comment on 'as-built' switchgear drawings. Any deficiencies caused because of not coordinating switchgear-drawing approval beforehand, must be remedied by the Contractor/Customer at their expense. All switchgear drawings are subject to review and approval by EPC, and must include the following information:
  - i. Switchgear manufacturers contact information
  - ii. Project and job number
  - iii. Complete shipping address for the instrument transformers
  - iv. Full name and phone number(s) of the contact person(s)
  - v. The Customer shall supply and install a 13-Jaw meter base. For the current list of approved meter bases, refer to Appendix B.
- c) EPC shall provide the necessary current and potential transformers, and these can be either shipped to the switchgear manufacturer (with reasonable notice) or installed locally by the Customer/Contractor. EPC shall not be responsible for installing these transformers or performing any bus modifications. The IT compartment shall be lockable.
- d) The Customer shall supply and install a grounded 120VAC duplex receptacle, fed from a dedicated 15A single-pole breaker, routed via EMT conduit and located within 12" from the meter base. Wiring to the receptacle is to be the minimum length possible.
- e) The Customer or Contractor shall contact EPC Metering Department when conduit, IT's, meter base and 120VAC duplex receptacle have been installed. Allow a minimum of 10 working days for EPC staff to build and install the metering equipment.
- f) Interval meters shall be installed for all new or upgraded services where the monthly average peak demand over a calendar year could exceed 50 kW or greater.

### 3.5 Central Metering

- 3.5.1 Central metering can be provided by EPC at the customer's request. This involves the installation of IT's at the transformer location to meter secondary cables running to typically two or more buildings on the same property, typically installed in rural areas.
- 3.5.2 For single-phase installations, refer to drawings "MS-10C or MS-10E".
  - a) The Customer shall supply and install an EPC approved 5-jaw (5th jaw at 9 o'clock position) meter base with automatic bypass for the current circuit on the left side jaws. See Appendix B for approved meter bases.
- 3.5.3 For pole mounted CMS installations, all central metering equipment shall be located on the transformer pole. The pole shall be a minimum 45' Class 3 wood pole, supplied and installed by the Customer.
- 3.5.4 For pad mounted central metering the CT's shall be located inside the EPC pad mount transformer. The meter shall be located on 6"x6" pressure treated post(s) or a freestanding meter cabinet structure. See drawings listed in 3.5.2 for specific installation details.
- 3.5.5 The Customer shall supply and install a continuous 32mm (1") PVC conduit from the meter base/cabinet to the CT's.

- 3.5.6 Interval meters shall be installed for all new or upgraded services where the monthly average peak demand over a calendar year could exceed 50kW or greater.

### **3.6 Primary Metering**

- 3.6.1 Primary metering may be a requirement of EPC. A deposit payable in full to EPC is required before EPC orders such equipment. EPC shall retain ownership of primary metering equipment.
- 3.6.2 Each primary metered service shall be reviewed thoroughly and on an individual basis. The Customer and/or their agent shall submit to EPC all required switchgear and electrical single line drawings in a timely manner to allow for EPC 's reviews and comments.
- 3.6.3 Primary metering potential transformers in Customer owned switchgear shall be installed in a manner that permits fuse and/or PT replacement via:
- a) PT's and fuses mounted on a tilt-out drawer or slide-out tray, or
  - b) Fuses mounted on a slide-out tray with PT's in a separate compartment, allowing for all of the following positions:
    - i. connected
    - ii. isolated
    - iii. grounded
- 3.6.4 Provisions for padlocking to be provided for the connected and grounded positions of the PT drawer/tray. The primary metering cell shall be lockable.
- 3.6.5 The PT/fuse compartment(s) must be fully barriered from remaining compartments.
- 3.6.6 A system neutral is required inside the primary metering switch and IT compartment to accommodate a 3-phase, 4-wire primary metering installation (3 CT's and 3 PT's).
- 3.6.7 A 36" x 36" x 12" metering cabinet (stainless steel NEMA 3R if outdoors) is required with 1-1/4" continuous conduit from the meter cabinet to the primary IT compartment. The customer shall also supply and install a dedicated 120V, 15A receptacle inside the metering cabinet. Confirm all requirements with Enova prior to installation.
- 3.6.8 All clearances shall be in accordance with the Electrical Safety Code. Any field modifications shall be subject to Electrical Safety Authority (ESA) Inspection and Canadian Standards Association (CSA) field evaluation.
- 3.6.9 Contact EPC early in the design stage to begin the review process as additional standards and requirements for primary metering may apply. Note that EPC does not stock either Primary Metering Units (PMU's) or Primary Metering Transformers and that this equipment typically has long lead times.

### **3.7 Interval Metering**

- 3.7.1 Interval meters shall be installed for all new or upgraded services where the monthly average peak demand over a calendar year could exceed 50 kW or greater. Some interval metering applications may require the installation of a third-party communication line for reading the meter. Once approved by the Ontario Energy Board (OEB), the Customer shall pay to EPC a Meter Communication Charge (or equivalent) for the communication line that is used to remotely read the customer's electric meter.

- 3.7.2 Metering applications that require a cellular or analogue communications include:
- i. Meters installed below grade with insufficient EPC private network coverage.
  - ii. Legacy customers that have read only access through ITRON MV90 software.
  - iii. Metering installations that are registered with the IESO.

### 3.8 Generation Metering

This section defines the metering requirements for embedded generators connected to EPC's distribution system. This section applies to the following types of generation:

- i. Net metering
  - ii. Load displacement generators
- 3.8.2 Each distributed generation service with the exception of Micro Generators (<10kW Capacity) shall be reviewed thoroughly and on an individual basis. The Customer and/or their agent shall submit to EPC all required switchgear and electrical single line drawings in a timely manner to allow for EPC 's reviews and comments. The metering installation shall be installed in accordance with the Connection Impact Assessment, Connection Cost Agreement, Distribution Connection Agreement, and Conditions of Service.
- 3.8.3 The Customer should contact EPC Engineering early in the design stage to begin the review as additional requirements for distribution system upgrades, remote Supervisory Control and Data Acquisition (SCADA) monitoring and transfer trip may apply.

#### Net Metering

- 3.8.4 EPC will install, at the Customers' cost, a bi-directional meter at the service entrance to measure energy in the delivered and received directions.
- 3.8.5 Net Metered services that have a total capacity greater than 50kW shall supply a second bi-directional meter at the generator output. The generator meter will be used for power quality monitoring and a future capacity reserve charge (or equivalent) once approved by the Ontario Energy Board. Refer to drawing "MS-50A, MS-50B or MS-50C" for equipment requirements and layout details.

#### Load Displacement Generators:

- 3.8.6 Load displacement generators that have a total nameplate capacity greater than 50kW shall supply a second meter at the generator output. The generator meter will be used for power quality monitoring and a future capacity reserve charge (or equivalent) if approved by the Ontario Energy Board. Refer to drawing "MS-50A, MS-50B, and MS-50C" for equipment requirements and layout details.
- 3.8.7 Load displacement generators greater than 1MW may be subject to Hydro One gross load billing charges and IESO meter registration. Projects above the 1MW threshold are reviewed on an individual basis and may be subject to additional standards and requirements.

#### Emergency Backup Generators

- 3.8.8 EPC Customers are allowed to purchase portable emergency backup generators. These generators must be installed on the load side of the EPC metering equipment.

- 3.8.9 For portable emergency backup generation, residential Customers can install an EPC approved plug-in transfer device onto a 200A, 4-jaw meter base that is installed outdoors. Before installation of a plug-in transfer device Customers must contact EPC's Engineering Department, sign an "Approved Meter-Base Transfer Device Waiver and Release Form", and receive an Offer to Connect Layout from the Engineering department authorizing the installation of the plug-in transfer device. See Appendix C for approved plug-in transfer devices.
- 3.8.10 Customers may install a combination meter base with service entrance rated breaker and automatic transfer switch. The combination meter must be installed outdoors and shall only be allowed for residential Customers with 120/240V, single phase services up to 200 Amps. See Appendix C for approved combination meter bases.

### 3.9 Pulse Outputs

- 3.9.1 Customers may request access to EPC's real time meter data for supplying inputs to their energy management systems. For most three-phase services greater than 200 Amps, EPC will provide Customer access to certain KYZ metering pulse output(s) after completing a site review and quotation for the Customer.
- 3.9.2 The Customer shall be responsible for all costs associated with supplying access to the metering pulse outputs.
- 3.9.3 The "EPC Metering Pulse Output(s) Access Agreement" must be completed and sent to EPC for approval.

### 3.10 Fire Equipment Connection

- 3.10.1 If a separate service for a fire pump has been deemed necessary to comply with legislation, codes or regulations under emergency conditions involving a fire, EPC will offer it subject to the following additional requirements:
- i. A single line diagram showing the connection of the fire pump and meter base voltage and current ratings shall be submitted to EPC.
  - ii. The main disconnect and meter base for the fire pump service shall be located in the same room as the main breaker for the overall service.
- 3.10.2 Laminated warning cards must be located at both the main disconnect for the fire pump service and at the main disconnect for the main secondary service (permanently affixed). They must be red with white lettering and the lettering must be a minimum of 12.7mm (0.5") in size. The wording on these cards must be "Fire Pump Installed Ahead of Main Breaker. Two (2) separate points of secondary supply exist in this room. There is a possibility of electrical back feed."

## **4. APPENDICIES**

## Appendix 'A'

# Metering Standards

Standard Number	Standard Title
MS-1	Multiple-Unit Metering Identification Detail
MS-2	Bonding, Metering Cabinets, Electronic Metering – Equipment Layout
MS-10A	Single To Multiple Unit Metering Up To And Including 200 Amps, 120/240V, Single And Ganged Meter Bases, Underground Service – Equipment Layout
MS-10B	Multiple Unit Metering, Up To And Including 200 Amps Per Metered Sub-Service, 120/240V, Ganged Meter Bases, Underground or Overhead Service – Load Side Wiring Configuration Specification
MS-10C	Central Metered Pad Mount, Single Phase, 200-600 Amp, 120/240V Service – Equipment Layout
MS-10D	400 Amp, Single-Phase, 120/240V With Transformer-Rated Combination Meter Base – Overhead or Underground Service - Equipment Layout
MS-10E	Central Metered Service, 200Amp To 600 Amp, 120/240V – Pole Mounted Transformer
MS-10F	400 Amp, Single-Phase, 120/240V With Meter Cabinet
MS-20A	Multiple Unit Metering, Below 225 Amps – 120/240V, 120/208V And 347/600V Without Meter Centre – Equipment Layout
MS-20B	Multiple Unit Metering, Up to 200A – 120/240V, 120/208V And 347/600V With Meter Centre – Equipment Layout
MS-30A	Meter Base – Standard Mounting Layout for Three Phase, Secondary Services With Low-Voltage Switchgear, 120/208V or 347/600V
MS-30B	Multiple Unit Metering, Combination of Services Below And Above 225 Amps – 120/240V, 120/208V And 347/600V – Equipment Layout
MS-30C	Multiple Unit Metering – Combination of Service Sizes With Transformer Discount Meter – 120/240V, 120/208V And 347/600V – Equipment Layout
MS-30D	Meter Cabinet – Standard Mounting Layout For Three Phase, Secondary Services 225-800 Amps Without Switchgear

<b>Standard Number</b>	<b>Standard Title</b>
MS-50A	Meter Base – Standard Mounting Layout For Three Phase, Distributed Generation Secondary Services, 120/208V or 347/600V Below 225A
MS-50B	Meter Cabinet – Standard Mounting Layout For Distributed Generation Secondary Services, 120/208V or 347/600V, 225-800 Amps Without Switchgear, With Scada
MS-50C	Meter Cabinet – Standard Mounting Layout For Distributed Generation Secondary Services, 120/208V or 347/600V, 225-800 Amps Without Switchgear, Without Scada

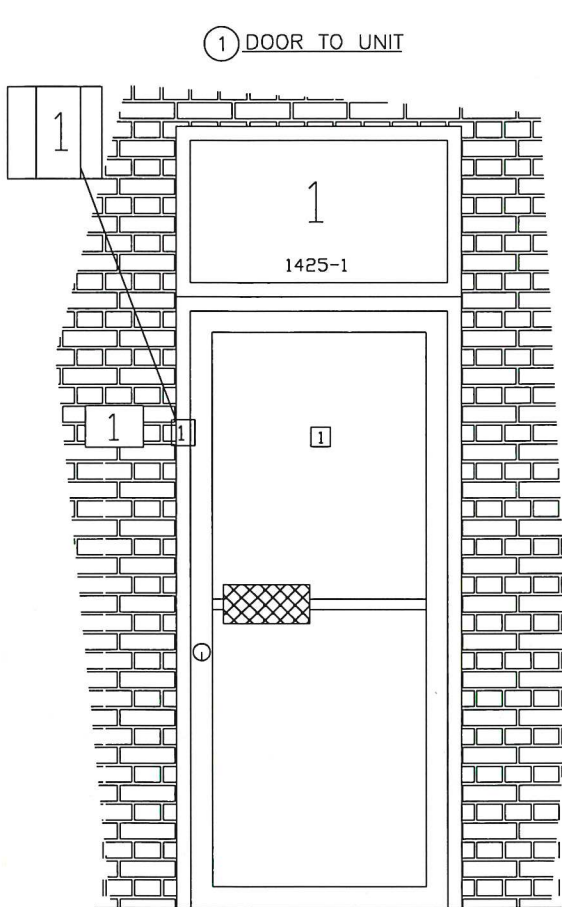

② UNIT MAIN SWITCH/BREAKER

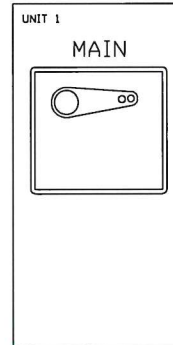

③ UNIT METER BASE

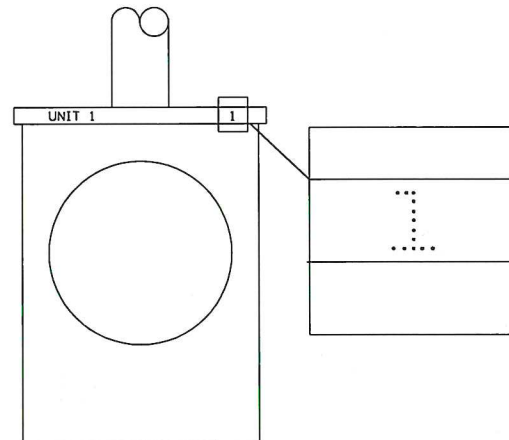

- ① UNIT NUMBER MUST BE PERMANENTLY MARKED, EASILY IDENTIFIABLE AND A MINIMUM TEXT SIZE OF 50mm (2"). PERMANENT MARKER OR NUMBERS ON PAPER TAPED TO DOOR ARE NOT ACCEPTABLE MEANS OF UNIT IDENTIFICATION
- ② UNIT NUMBER MUST BE PERMANENTLY MARKED ON MAIN SWITCH/BREAKER. PERMANENT MARKER ACCEPTABLE ON INDOOR EQUIPMENT
- ③ UNIT NUMBER MUST BE PERMANENTLY MARKED ON NON-REMOVABLE PORTION OF METER BASE (AS SHOWN) AND ALSO MARKED ON THE INSIDE OF THE METER BASE. ACCEPTABLE MEANS OF MARKING INCLUDE ENGRAVED WITH ELECTRIC ETCHER, CENTER PUNCH DOTS (AS SHOWN), PAINT OR PERMANENT MARKER. PERMANENT MARKER ONLY ACCEPTABLE ON INDOOR EQUIPMENT
- ④ STREET ADDRESS FOR BUILDING MUST BE CLEARLY POSTED
- ⑤ UNITS NOT SUFFICIENTLY IDENTIFIED WILL NOT BE CONNECTED UNTIL IN COMPLIANCE WITH THIS STANDARD

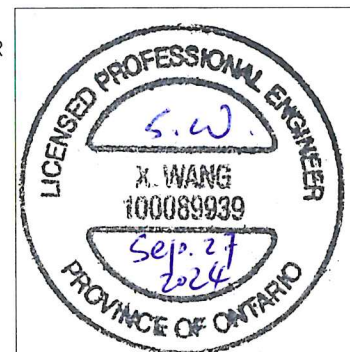

**Certificate of Approval**

The installation work covered by this document meets the safety requirements of Section 4 of Regulation 22/04

 Shawn Wang *S.W.* Sep. 27, 2024  
 Date

  
 Signature & Professional Designation

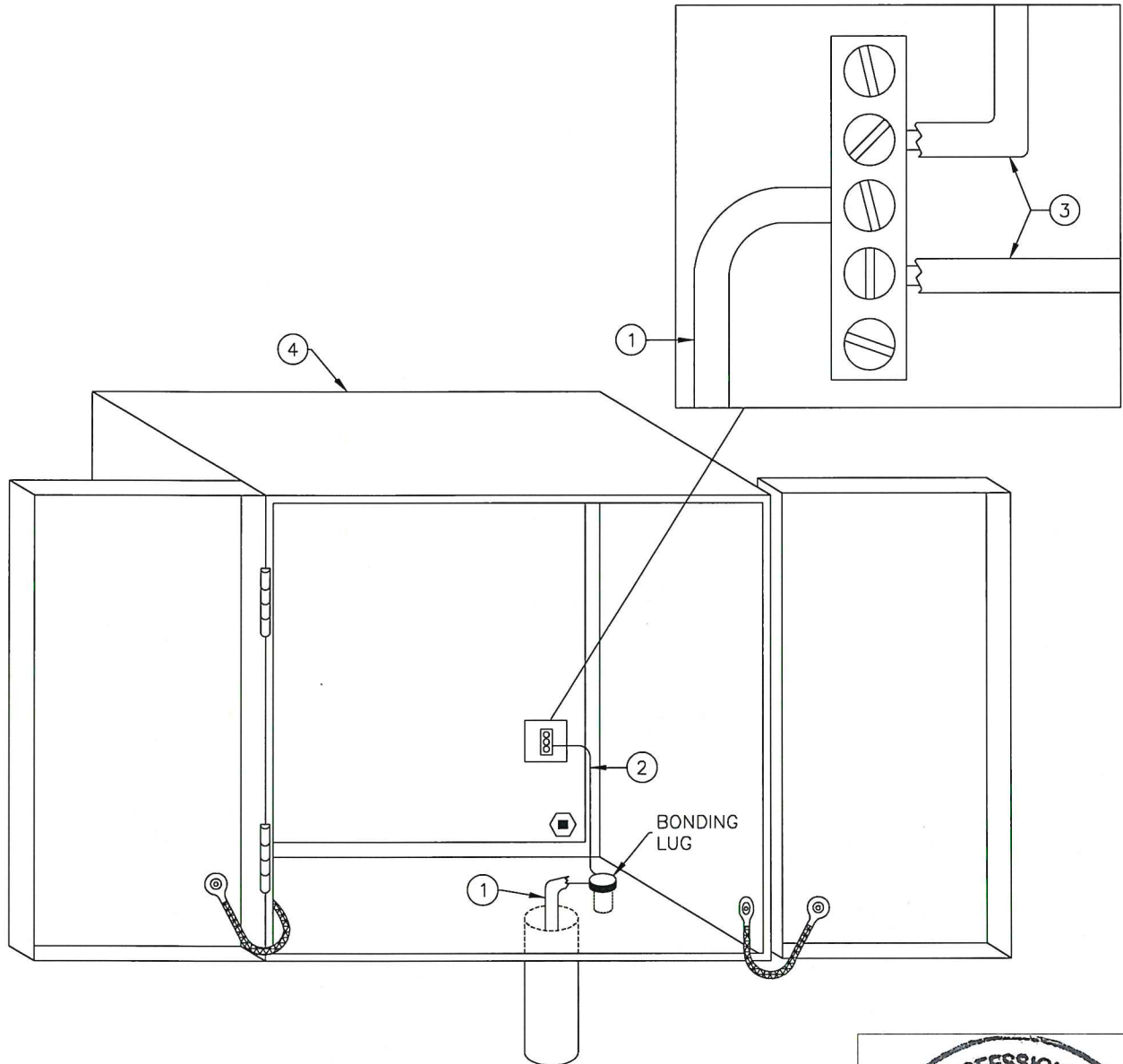
REV.	DESCRIPTION	DATE	INITIALS
1	UPDATED TO NEW DRAFTING STANDARD	03/23/2021	BD
2	ENOVA STANDARDS UPDATE	02/22/2024	RO



- ① #6 CU (GREEN INSULATION) TO MAIN SERVICE GROUND SUPPLIED AND INSTALLED BY CUSTOMER/CONTRACTOR
- ② 150mm TO 200mm (6" TO 8") AFTER ENTERING CABINET, TERMINATE AT BONDING LUG AND CONTINUE TAIL TO LOWER RIGHT CORNER OF BACK PLATE
- ③ #12 CU (GREEN INSULATION) TO HYDRO METERING EQUIPMENT AND BOND CONNECTOR
- ④ METERING CABINET TO BE COMPLETE WITH A REMOVABLE BACK PLATE & TWO (2) SIDE HINGED OPENING DOORS

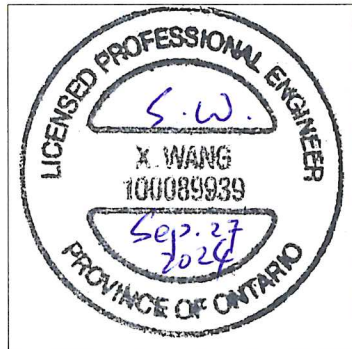

• MAINTAIN A MINIMUM 1m (39") CLEARANCE IN FRONT OF METER BASE(S) AND INSTRUMENT TRANSFORMER COMPARTMENT(S)

**Certificate of Approval**  
The installation work covered by this document meets the safety requirements of Section 4 of Regulation 22/04

REV.	DESCRIPTION	DATE	INITIALS
1	UPDATED TO NEW DRAFTING STANDARD	03/23/2021	BD
2	ENOVA STANDARDS UPDATE	02/22/2024	RO

Signature: *Shaun Wang* Date: *Sep. 27, 2024*  
Signature & Professional Designation: *P. Eng.*

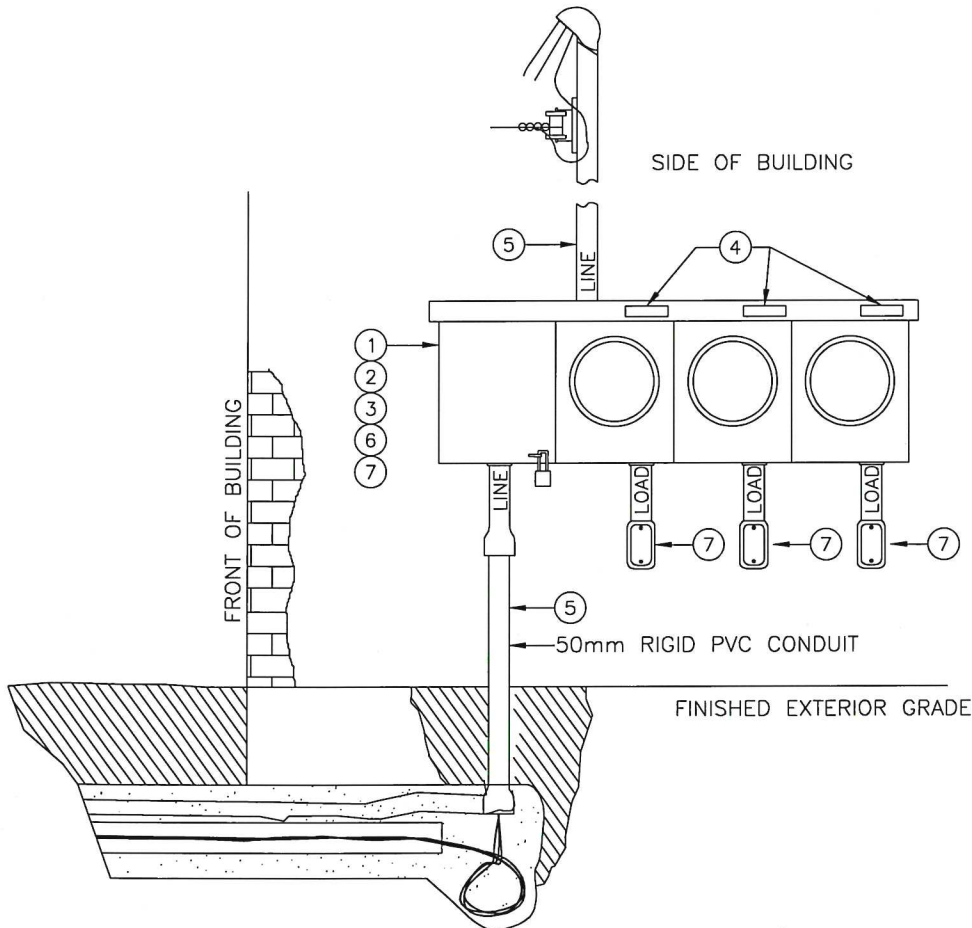

- ① METER BASE(S) TO BE LOCATED ON EXTERIOR OF BUILDING AND MOUNTED AT 1.5m (5'0") ± 150mm (6") FROM FINISHED ELEVATION TO CENTER OF METER GLASS/FACE. SEE SELECTION TABLE IN APPENDIX B FOR APPROVED METER BASES
  - ② METER BASE(S) TO BE WITHIN 3m (118") OF FRONT CORNER OF BUILDING
  - ③ BLANK COMPARTMENT WITH PROVISIONS FOR AN EXTERNAL PADLOCK IS REQUIRED FOR ALL U/G MULTI-POSITION METER BASES
  - ④ METERING SPECIFICATIONS MS-1 AND MS-10B APPLY FOR MULTI-UNIT METERING INSTALLATIONS
  - ⑤ CABLE AND CONDUIT LOCATIONS FOR LINE/LOAD CONDUCTORS MAY VARY DEPENDING ON OVERHEAD OR UNDERGROUND FEED CONFIGURATION.
  - ⑥ ENOVA OWNED U/G SERVICE CABLES MUST RUN DIRECTLY INTO THE BLANK COMPARTMENT. BLANK COMPARTMENT SHALL BE USED FOR ENOVA'S SERVICE CABLES ONLY.
  - ⑦ FOR U/G GANGED METER BASES, THE CUMULATIVE NAMEPLATE RATING OF ALL PANELS SHALL NOT EXCEED 400A WHEN THE GANGED METER BASE IS FED FROM A SINGLE RUN OF ENOVA OWNED U/G CABLE.
- METER BASE SHALL BE MOUNTED AND SECURED TO WALL AS PER ELECTRICAL SAFETY AUTHORITY (ESA) REQUIREMENTS. RECESSED METER BASES ARE NOT PERMITTED.
  - NO PART OF METER BASE(S) IS PERMITTED TO BE ABOVE CENTRAL AIR CONDITIONERS, WINDOW WELLS OR ANY OBSTABLES THAT PREVENT ACCESS TO METER
  - NO PART OF METER BASE IS PERMITTED WITHIN 1m (39") OF THE DISCHARGE OPENING OF A NATURAL GAS METER RELIEF DEVICE (VENT).
  - MAINTAIN A MINIMUM 1m (39") CLEARANCE IN FRONT OF METER BASE(S)



**Certificate of Approval**  
 The installation work covered by this document meets the safety requirements of Section 4 of Regulation 22/04

Signature: *Shawn Wang* Date: *May 27 2025*  
 Signature: *[Signature]* P. Eng.  
 Signature & Professional Designation

REV.	DESCRIPTION	DATE	INITIALS
4	NOTES UPDATED	02/14/2025	BM
5	CONDUIT NOTE ADDED	05/07/2025	BM
6	NOTES UPDATED	05/27/2025	BM



DATE:  
2025-05-27

SCALE:  
NTS

REV.  
6

DWG. NO. MS-10B

TITLE: MULTIPLE UNIT METERING, UP TO AND INCLUDING 200 AMPS PER METERED SUB-SERVICE, 120/240V, GANGED METER BASES, UNDERGROUND OR OVERHEAD - LOAD SIDE WIRING CONFIGURATION SPECIFICATION

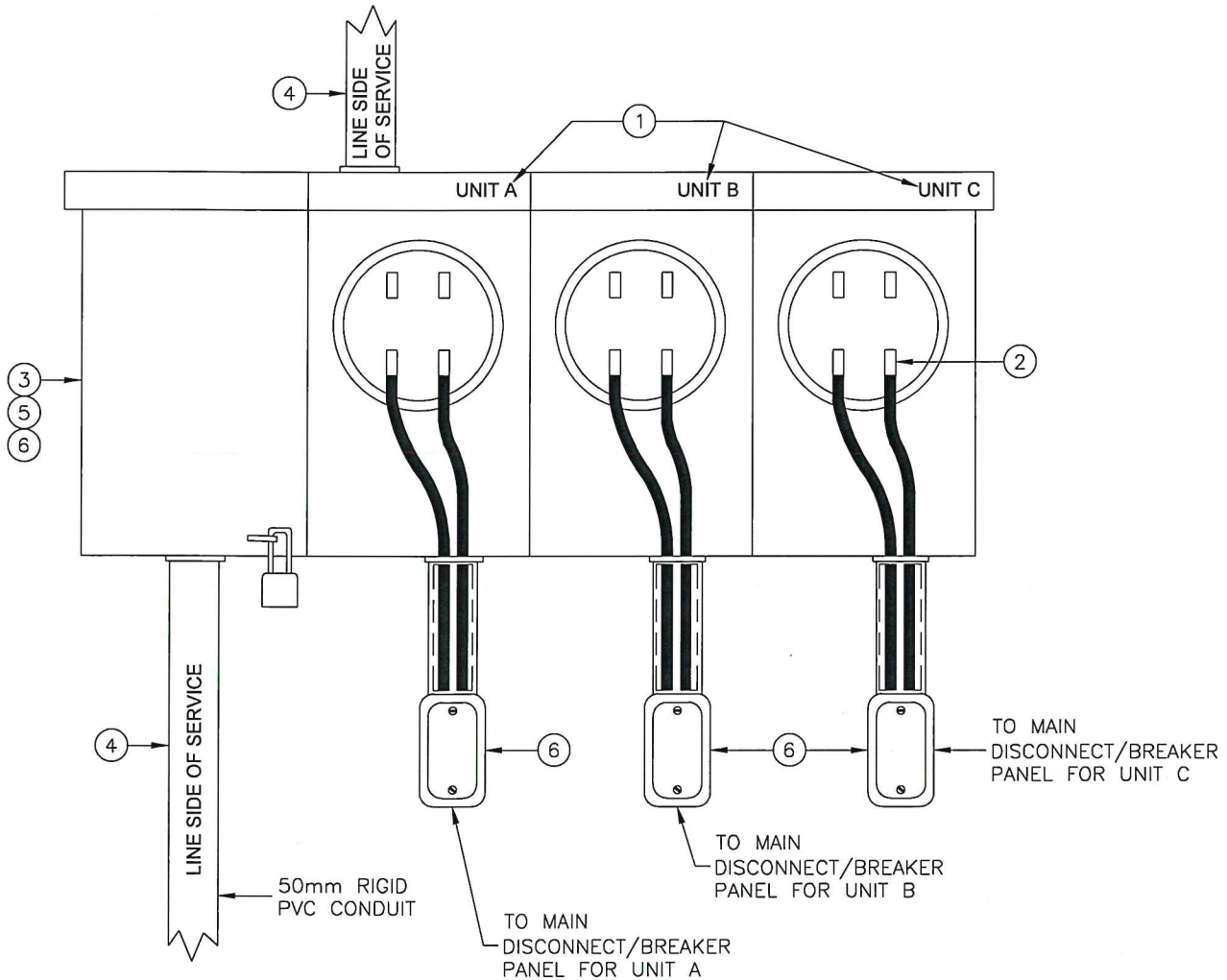

- ① UNIT NUMBERING ON METER BASE AS PER SPECIFICATION DRAWING MS-1
- ② LOAD SIDE OF HYDRO METER
- ③ BLANK COMPARTMENT WITH PROVISIONS FOR AN EXTERNAL PADLOCK IS REQUIRED FOR ALL U/G MULTI-POSITION METER BASES
- ④ CABLE AND CONDUIT LOCATIONS FOR LINE/LOAD CONDUCTORS MAY VARY DEPENDING ON OVERHEAD OR UNDERGROUND FEED CONFIGURATION
- ⑤ ENOVA OWNED U/G SERVICE CABLES MUST RUN DIRECTLY INTO THE BLANK COMPARTMENT. BLANK COMPARTMENT SHALL BE USED FOR ENOVA'S SERVICE CABLES ONLY
- ⑥ FOR U/G GANGED METER BASES, THE CUMULATIVE NAMEPLATE RATING OF ALL PANELS SHALL NOT EXCEED 400A WHEN THE GANGED METER BASE IS FED FROM A SINGLE RUN OF ENOVA OWNED U/G CABLE.

- METER BASES TO NOT BE USED AS RACE WAY
- MAINTAIN A MINIMUM 1m (39") CLEARANCE IN FRONT OF METER BASE(S)

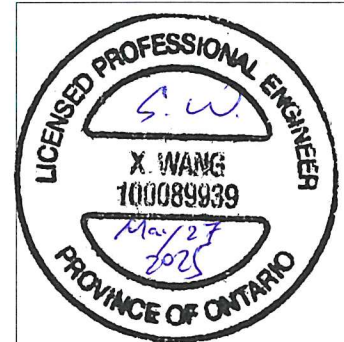

**Certificate of Approval**  
 The installation work covered by this document meets the safety requirements of Section 4 of Regulation 22/04  
*Shawn Wang* May 27, 2025  
 Date  
*P. Eng.*  
 Signature & Professional Designation

REV.	DESCRIPTION	DATE	INITIALS
4	NOTES UPDATED	02/14/2025	BM
5	CONDUIT NOTE ADDED	05/07/2025	BM
6	NOTES UPDATED	05/27/2025	BM

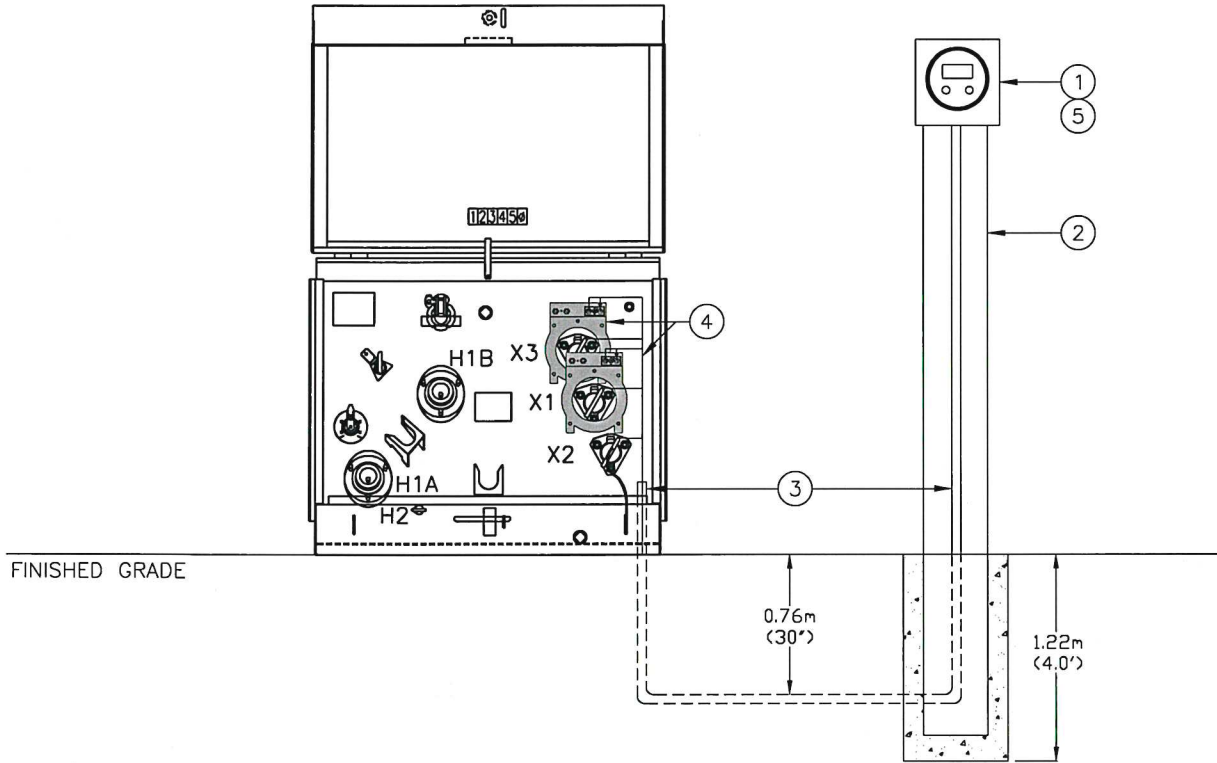

- ① CUSTOMER/CONTRACTOR TO SUPPLY & INSTALL AN EPC APPROVED 5-JAW METER BASE (5TH JAW IN THE 9 O'CLOCK POSITION) WITH AUTOMATIC BYPASS AT THE CURRENT CIRCUIT ON THE LEFT SIDE. METER BASE TO BE MOUNTED AT 1.5m (5'0") ± 150mm (6") FROM FINISHED GRADE ELEVATION TO CENTER OF METER. SEE APPENDIX B SELECTION TABLE FOR APPROVED METER BASES
- ② FREE STANDING STRUCTURE SPECIFICATIONS:
  - a. 1 – 6"X6"X10' PRESSURE TREATED POST (MINIMUM 1.22m (4') INSTALLED SUB-GRADE
  - b. POSTS TO BE CONCRETE ENCASED IN MINIMUM 1.22m (4') DEEP SONOTUBES
  - c. POST TO BE LOCATED WITHIN 1m OF TRANSFORMER VAULT (INSIDE TRANSFORMER GROUNDING LOOP)
- ③ 25mm (1") PVC CONDUIT—MUST BE CONTINUOUS FROM ABOVE FINISHED GRADE IN PAD MOUNT TRANSFORMER TO METER BASE
- ④ HYDRO WILL SUPPLY AND INSTALL METERING C.T.'S AND METERING WIRE
- ⑤ ELECTRICAL CONTRACTOR TO SUPPLY SUFFICIENT #6 GREEN WIRE TO BOND METER CABINET TO TRANSFORMER.

- SEE EPC UNDERGROUND STANDARDS DOCUMENT FOR TRANSFORMER AND CABLE INSTALLATION DETAILS
- MAINTAIN A MINIMUM 1m (39") CLEARANCE IN FRONT OF METER BASE(S) AND INSTRUMENT TRANSFORMER COMPARTMENT(S)

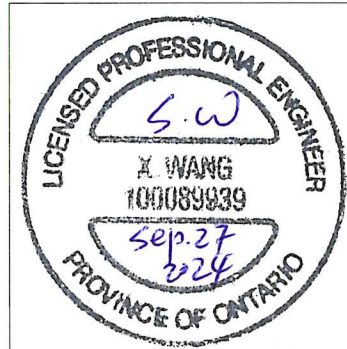

**Certificate of Approval**  
The installation work covered by this document meets the safety requirements of Section 4 of Regulation 22/04

Shawn Wang      Sep. 27, 2024  
 Date

P. Eng  
 Signature & Professional Designation

REV.	DESCRIPTION	DATE	INITIALS
1	STANDARD CREATED	03/23/2021	BD
2	ENOVA STANDARDS UPDATE	02/22/2024	RO
3	ENOVA STANDARDS UPDATE	05/30/2024	BD

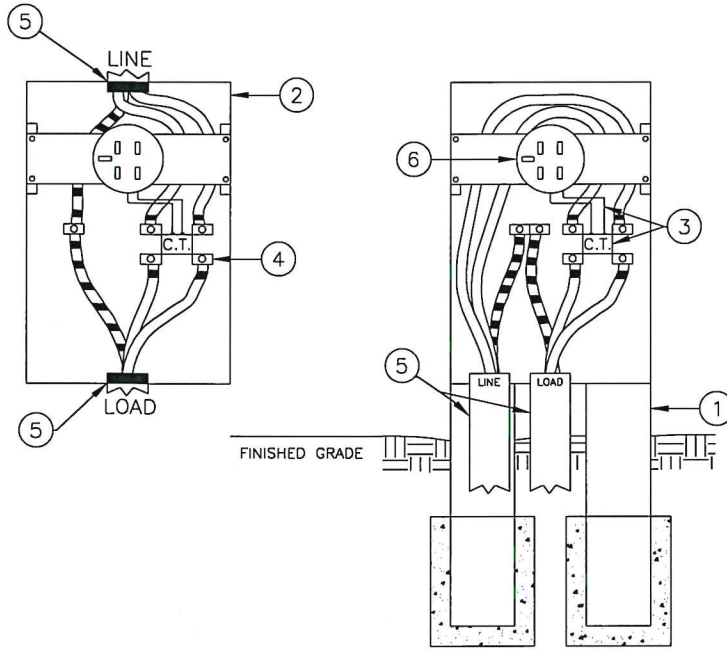

FREE STANDING STRUCTURE  
 CONSTRUCTION DETAIL:  
 \*SEE NOTE 1 FOR REQUIREMENTS\*

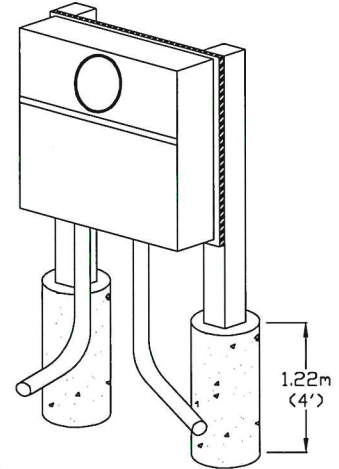

- ① FREE STANDING STRUCTURE SPECIFICATIONS:
  - a. 2 - 6"X6"X10' PRESSURE TREATED POSTS (MINIMUM 1.22m (4')) INSTALLED SUB-GRADE
  - b. POSTS TO BE CONCRETE ENCASED IN MINIMUM 1.22m (4') DEEP SONOTUBES
  - c. BACKBOARD TO BE 16mm (5/8") OR 19mm (3/4") PLYWOOD WITH 25.4mm (1") OVERLAP ON ALL SIDES OF METER ENCLOSURE
- ② METER BASE DIMENSIONS (APPROXIMATE) 750mm X 460mm X 200mm (30" X 18" X 8") TO BE MOUNTED AT 1.5m (5'0") ± 150mm (6") FROM FINISHED GRADE ELEVATION TO CENTER OF METER. SEE APPENDIX B SELECTION TABLE FOR APPROVED METER BASES
- ③ ENOVA TO PROVIDE CURRENT TRANSFORMER (C.T.) AND WIRING ON SECONDARY SIDE OF C.T.
- ④ CUSTOMER/CONTRACTOR TO SUPPLY AND INSTALL ALL LUGS FOR CONNECTIONS ON PRIMARY SIDE OF C.T.
- ⑤ CABLE CONDUIT LOCATIONS FOR LINE/LOAD CONDUCTORS MAY VARY DEPENDING ON OVERHEAD OR UNDERGROUND FEED CONFIGURATION
- ⑥ 5-JAW METER BASE MUST BE EQUIPPED WITH AN AUTOMATIC BYPASS SWITCH FOR THE CURRENT CIRCUIT WITH 5TH JAW IN 9 O'CLOCK POSITION

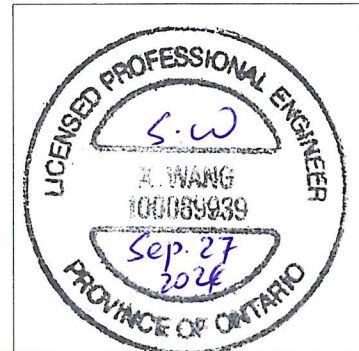

- MAINTAIN A MINIMUM 1m (39") CLEARANCE IN FRONT OF METER BASE(S) AND INSTRUMENT TRANSFORMER COMPARTMENT(S)

**Certificate of Approval**  
 The installation work covered by this document meets the safety requirements of Section 4 of Regulation 22/04

Date  
**Sep. 27, 2024**

**PENG**

Signature & Professional Designation

REV.	DESCRIPTION	DATE	INITIALS
0	CREATION OF STANDARD	03/23/2024	CA
1	ENOVA STANDARDS UPDATE	05/30/2024	BD

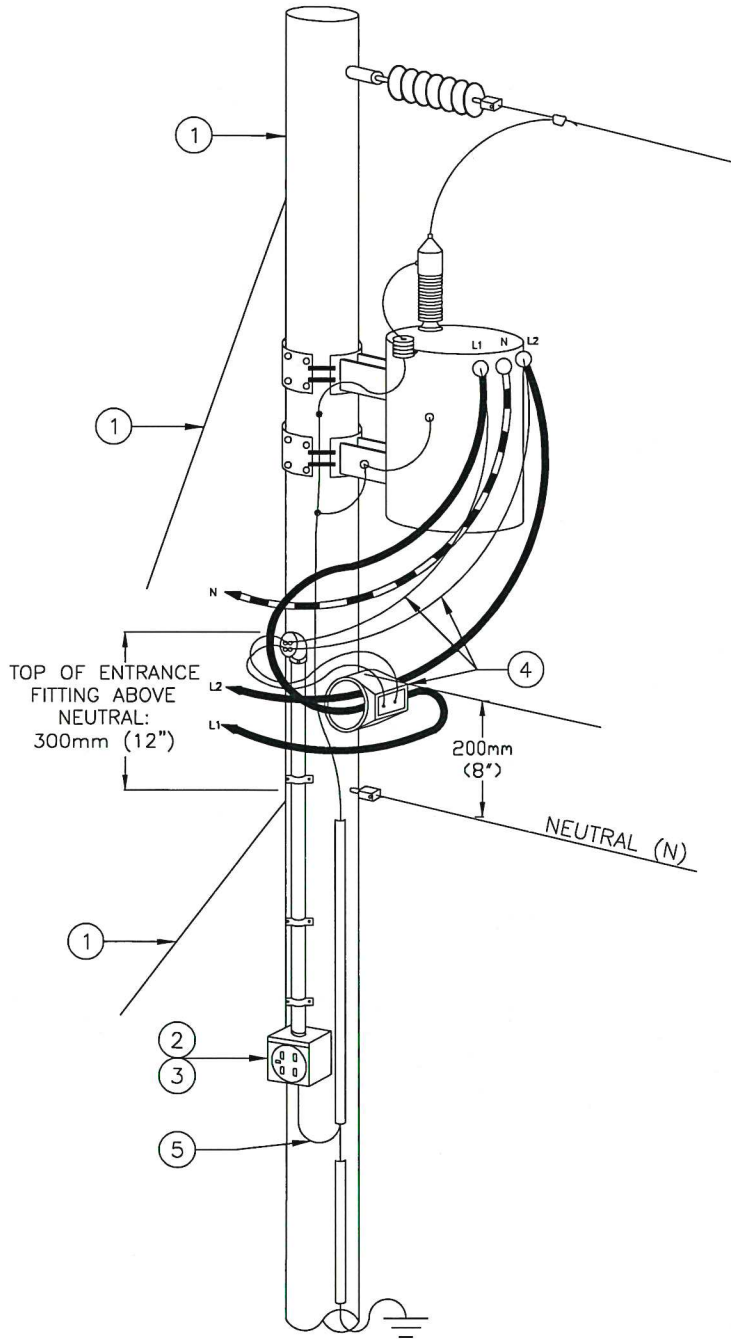

- ① CUSTOMER-OWNED TRANSFORMER POLE MUST BE:
  - a. SUPPLIED & INSTALLED BY CUSTOMER/CONTRACTOR (LOCATION SUBJECT TO HYDRO APPROVAL)
  - b. MINIMUM 45' CLASS 3 WOOD, PRESSURE-TREATED BUTT (TREATED WITH AN APPROVED WOOD PRESERVATIVE) TO APPROXIMATELY 300mm (12") ABOVE GRADE. MINIMUM SETTING DEPTH OF POLE: 1.98m (6'6").
  - c. BACK-GUYED & ANCHORED AS PER ESA (1.37m (54") FIBERGLASS ROD SHALL BE USED ON ALL GUYS)
  - d. FRAMED & INSULATED FOR 27.6KV OPERATING VOLTAGE
- ② METER BASE MOUNTING HEIGHT MUST BE 1.5m (5'0") ±150mm (6") FROM FINISHED GRADE TO CENTER OF METER FACE/GLASS
- ③ CUSTOMER/CONTRACTOR TO SUPPLY & INSTALL AN APPROVED 5-JAW METER BASE (5TH JAW IN THE 9 O'CLOCK POSITION) WITH AUTOMATIC BYPASS AT THE CURRENT CIRCUIT ON THE LEFT SIDE AND A 25mm (1") PVC CONDUIT UP THE POLE, COMPLETE WITH WEATHER HEAD AT SPECIFIED HEIGHT. SEE APPENDIX B SELECTION TABLE FOR APPROVED METER BASES
- ④ HYDRO WILL SUPPLY & INSTALL THE METERING CT AND METERING WIRE
- ⑤ #6 BOND WIRE TO BE INSTALLED BY CUSTOMER/CONTRACTOR

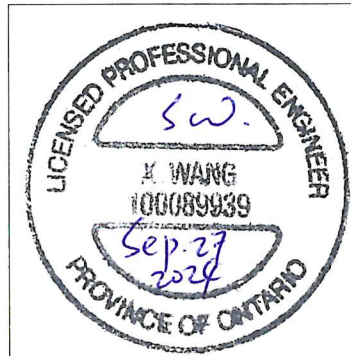

- MAINTAIN A MINIMUM 1m (39") CLEARANCE IN FRONT OF METER BASE(S) AND INSTRUMENT TRANSFORMER COMPARTMENT(S)

**Certificate of Approval**

The installation work covered by this document meets the safety requirements of Section 4 of Regulation 22/04

 Shaun Wang, Sep. 27, 2024  
 Date

  
 Signature & Professional Designation

REV.	DESCRIPTION	DATE	INITIALS
1	UPDATED TO NEW DRAFTING STANDARD	03/23/2021	BD
2	ENOVA STANDARDS UPDATE	02/22/2024	RO
3	ENOVA STANDARDS UPDATE	05/30/2024	BD

## TITLE: METER CABINET - STANDARD MOUNTING LAYOUT FOR SINGLE PHASE, SECONDARY SERVICES 225-600 AMPS WITHOUT SWITCHGEAR

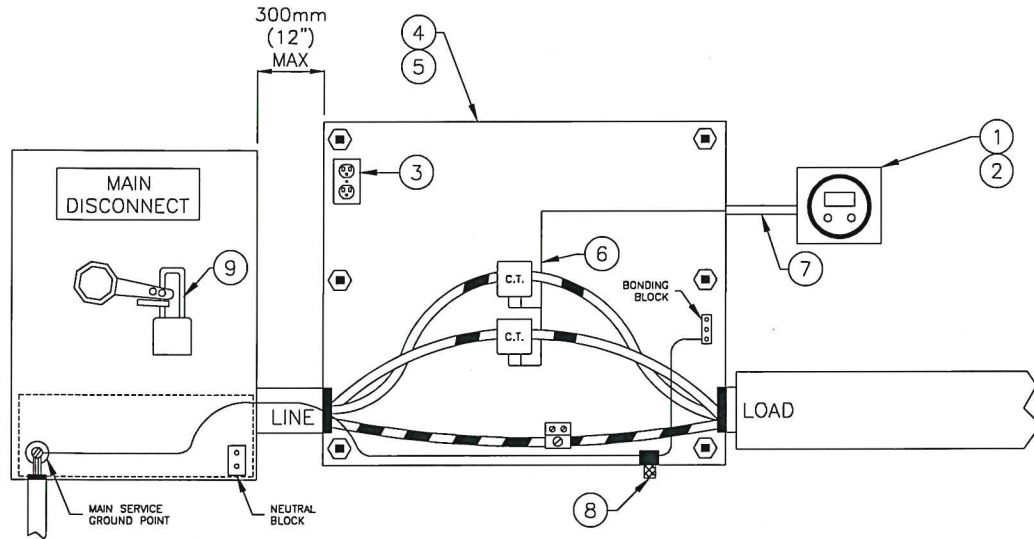

FINISHED FLOOR ELEVATION

- ① CUSTOMER/CONTRACTOR TO SUPPLY & INSTALL AN APPROVED 5-JAW METER BASE (5TH JAW IN THE 9 O'CLOCK POSITION) WITH AUTOMATIC BYPASS AT THE CURRENT CIRCUIT ON THE LEFT SIDE. METER BASE TO BE MOUNTED ON EXTERIOR WALL AT 1.5m (5'0") ± 150mm (6") FROM FINISHED GRADE ELEVATION TO CENTER OF METER. SEE APPENDIX B SELECTION TABLE FOR APPROVED METER BASES.
- ② METER BASE TO BE WITHIN 3m (118") OF FRONT CORNER OF BUILDING.
- ③ GROUNDED 120VAC DUPLEX RECEPTACLE – FED FROM DEDICATED 15A SINGLE POLE BREAKER, SUPPLIED & INSTALLED BY CUSTOMER'S CONTRACTOR.
- ④ METER CABINET DIMENSIONS 900mm x 900mm x 300mm (36"x36"x12") OR ALTERNATE SIZE OF 1200mm x 1200mm x 300mm (48"x48"x12") COMPLETE WITH REMOVABLE BACK PLATE AND 2 SIDE-HINGED CENTER OPENING DOORS. CABINET TO BE MOUNTED AT A HEIGHT OF 1.83m (6') ± 50mm (2") FROM FINISHED FLOOR ELEVATION TO TOP OF CABINET. FOR OUTDOOR INSTALLATIONS, A STAINLESS STEEL NEMA 3R CABINET IS REQUIRED COMPLETE WITH A 200W HEATER (HEATER BY CUSTOMER).
- ⑤ METER CABINET MUST BE SECURELY FASTENED TO SUPPORTING WALL WITH AN ADEQUATE NUMBER OF PROPERLY SIZED FASTENERS TO SUPPORT A FULLY LOADED CABINET AND BACK PLATE ASSEMBLY WEIGHT OF 90KG (200LBS)
- ⑥ FUSING REQUIRED ON POTENTIAL CONDUCTORS IF CONDUCTOR LENGTH IS >3m (118")
- ⑦ 25mm (1") EMT OR PVC CONDUIT MAXIMUM LENGTH 15m (50') OF CONDUIT—MUST BE CONTINUOUS FROM METER CABINET TO METER BASE.
- ⑧ BONDING LUG AS PER DRAWING MS-2.
- ⑨ MAIN DISCONNECT MUST BE LOCKABLE.

- ALL METERING CT'S AND PT'S TO BE LOCATED ON LOAD SIDE OF MAIN DISCONNECT
- MAINTAIN A MINIMUM 1m (39") CLEARANCE IN FRONT OF METER BASE(S) AND INSTRUMENT TRANSFORMER COMPARTMENT(S)

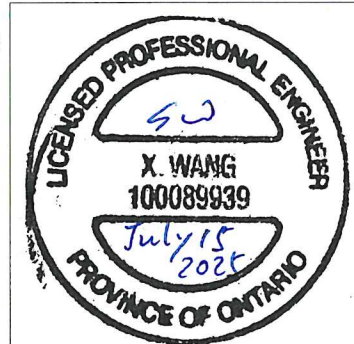

**Certificate of Approval**  
 The installation work covered by this document meets the safety requirements of Section 4 of Regulation 22/04

*Shaun Wang*     *July 15, 2025*  
 Date  
*P. Eng.*  
 Signature & Professional Designation

REV.	DESCRIPTION	DATE	INITIALS
2	ENOVA STANDARDS UPDATE	02/22/2024	RO
3	ENOVA STANDARDS UPDATE	07/05/2024	BD
4	NOTE 4 REVISED	07/14/2025	BM

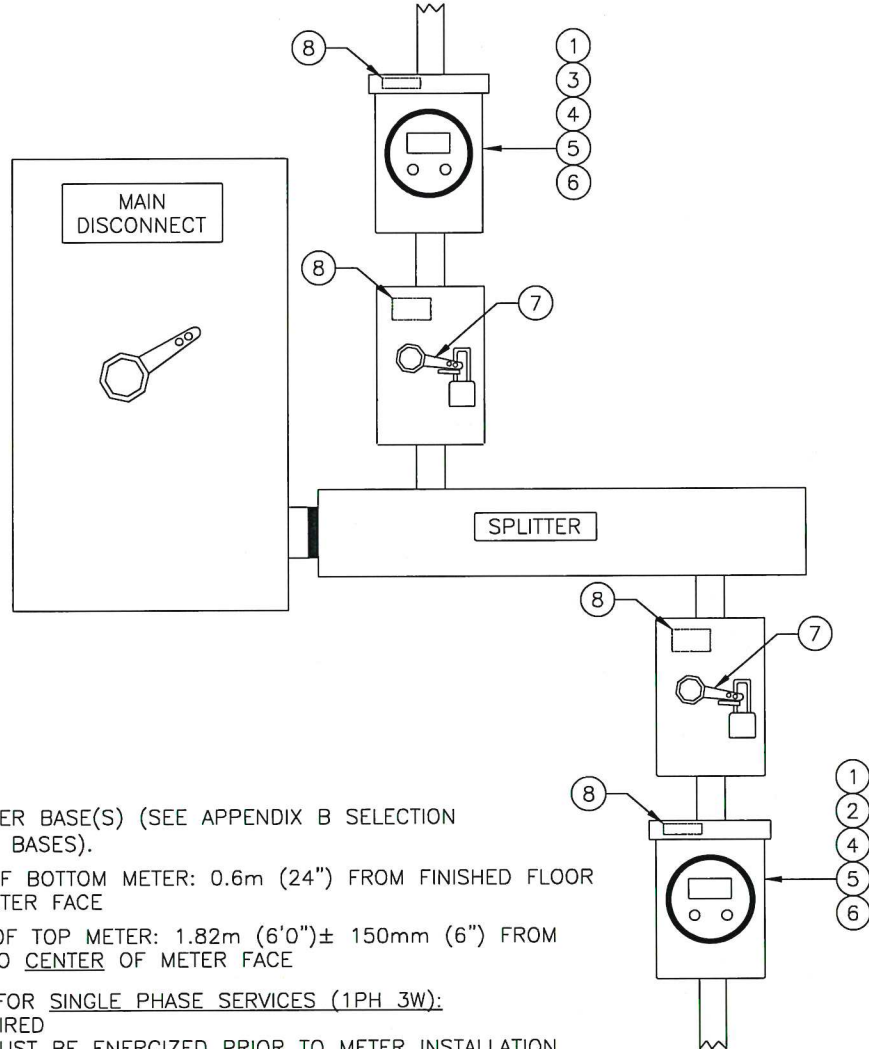

- ① APPROVED SUB-SERVICE METER BASE(S) (SEE APPENDIX B SELECTION TABLE FOR APPROVED METER BASES).
- ② MINIMUM MOUNTING HEIGHT OF BOTTOM METER: 0.6m (24") FROM FINISHED FLOOR ELEVATION TO CENTER OF METER FACE
- ③ MAXIMUM MOUNTING HEIGHT OF TOP METER: 1.82m (6'0") ± 150mm (6") FROM FINISHED FLOOR ELEVATION TO CENTER OF METER FACE
- ④ METER BASE REQUIREMENTS FOR SINGLE PHASE SERVICES (1PH 3W):
  - a. 4-JAW METER BASE REQUIRED
  - b. LINE SIDE CONDUCTORS MUST BE ENERGIZED PRIOR TO METER INSTALLATION
  - c. NEUTRAL CONDUCTOR MUST BE BROUGHT INTO AND TERMINATED IN EACH METER BASE
- ⑤ METER BASE REQUIREMENTS FOR THREE PHASE SERVICES (3PH 4W):
  - a. 7-JAW METER BASE REQUIRED
  - b. ALL THREE PHASES TO THE LINE SIDE OF THE METER BASE MUST BE ENERGIZED PRIOR TO METER INSTALLATION
  - c. NEUTRAL CONDUCTOR MUST BE BROUGHT INTO AND TERMINATED IN EACH METER BASE
- ⑥ METER BASE REQUIREMENTS FOR NETWORK SERVICES (2PH 3W):
  - a. 5-JAW METER BASE REQUIRED WITH 5TH JAW IN 9 O'CLOCK POSITION
  - b. BOTH PHASES TO THE LINE SIDE OF THE METER BASE MUST BE ENERGIZED PRIOR TO METER INSTALLATION
  - c. NEUTRAL CONDUCTOR MUST BE BROUGHT INTO AND TERMINATED IN EACH METER BASE
- ⑦ EACH SUB-SERVICE IS TO BE COMPLETE WITH LOCKABLE DISCONNECT
- ⑧ UNIT LABELING AS PER METERING SPECIFICATION MS-1

- **MAINTAIN A MINIMUM 1m (39") CLEARANCE IN FRONT OF METER BASE(S) AND INSTRUMENT TRANSFORMER COMPARTMENT(S)**

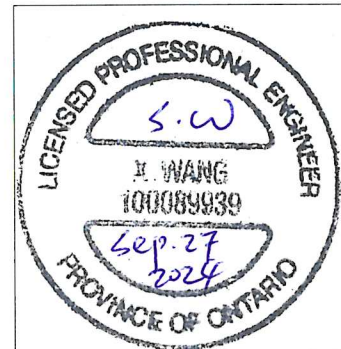

**Certificate of Approval**  
 The installation work covered by this document meets the safety requirements of Section 4 of Regulation 22/04

Shaun Wang Sep 27 2024  
 Date

P. Eng.  
 Signature & Professional Designation

REV.	DESCRIPTION	DATE	INITIALS
1	UPDATED TO NEW DRAFTING STANDARD	03/23/2021	BD
2	ENOVA STANDARDS UPDATE STANDARD	02/22/2024	RO
3	ENOVA STANDARDS UPDATE	05/30/2024	BD

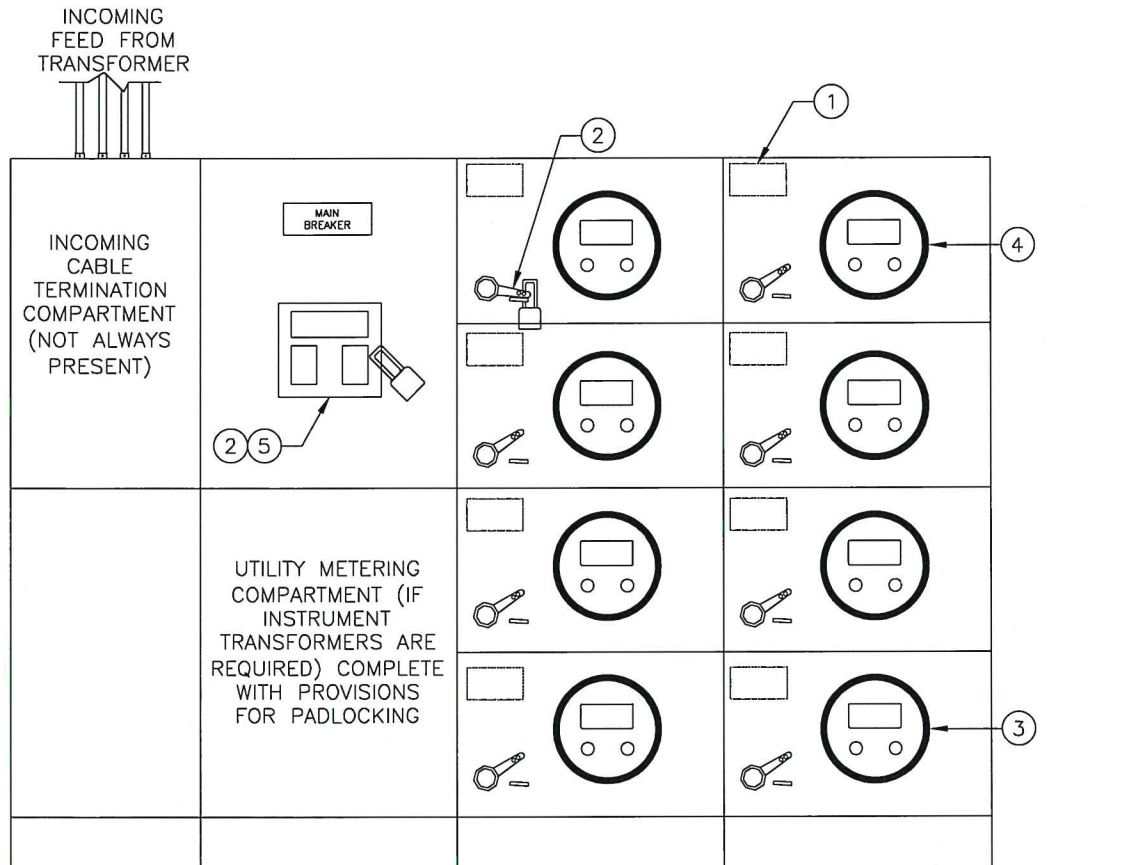

FINISHED FLOOR ELEVATION

- ① UNIT NUMBERING AS PER DRAWINGS MS-1
- ② ALL DISCONNECTS MUST BE LOCKABLE
- ③ MINIMUM MOUNTING HEIGHT OF BOTTOM METER: 0.6m (24") FROM FINISHED FLOOR ELEVATION TO CENTER OF METER FACE
- ④ MAXIMUM MOUNTING HEIGHT OF TOP METER: 1.82m (6'0") ± 150mm (6") FROM FINISHED FLOOR ELEVATION TO CENTER OF METER FACE
- ⑤ ALL ELECTRICAL INPUTS TO THIS EQUIPMENT MUST BE CONNECTED ON THE LOAD SIDE OF THE REVENUE METERING INSTRUMENTS, OUTSIDE OF THE METERING TRANSFORMER COMPARTMENT

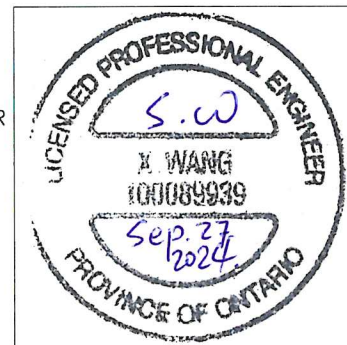

- MAINTAIN A MINIMUM 1m (39") CLEARANCE IN FRONT OF METER BASE(S) AND INSTRUMENT TRANSFORMER COMPARTMENT(S)

REV.	DESCRIPTION	DATE	INITIALS
1	UPDATED TO NEW DRAFTING STANDARD	03/23/2021	BD
2	ENOVA STANDARDS UPDATE STANDARD	02/22/2024	RO
3	ENOVA STANDARDS UPDATE	05/30/2024	BD

**Certificate of Approval**  
 The installation work covered by this document meets the safety requirements of Section 4 of Regulation 22/04

Shaun Wang *Signature*      Sep. 27, 2024 *Date*

*P. Eng* *Signature*      P. Eng *Designation*

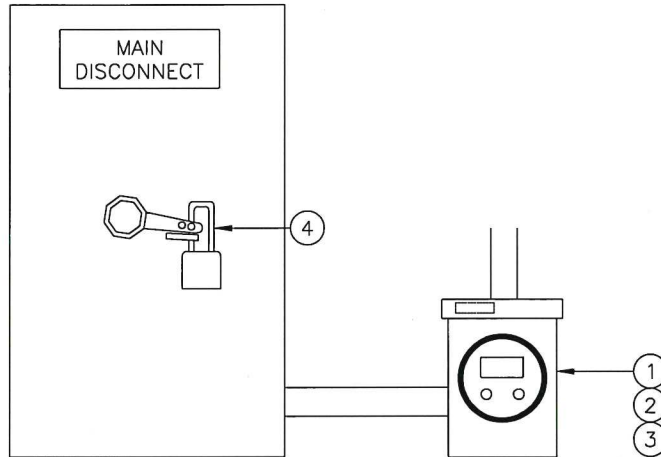

- ① APPROVED SUB-SERVICE METER BASE(S) WITH ISOLATED NEUTRAL BLOCK. METER BASE TO BE LOCATED ON GROUND LEVEL FLOOR AND MOUNTED AT 1.5m (5'0") ± 150mm (6") FROM FINISHED FLOOR ELEVATION TO CENTER OF METER. SEE APPENDIX B SELECTION TABLE FOR APPROVED METER BASES
- ② METER BASE REQUIREMENTS FOR THREE PHASE SERVICES (3PH 4W):
  - a. 7-JAW METER BASE REQUIRED
  - b. ALL THREE PHASES TO THE LINE SIDE OF THE METER BASE MUST BE ENERGIZED PRIOR TO METER INSTALLATION
  - c. NEUTRAL CONDUCTOR MUST BE BROUGHT INTO AND TERMINATED AT THE METER BASE
- ③ METER BASE REQUIREMENTS FOR NETWORK SERVICES (2PH 3W):
  - a. 5-JAW METER BASE REQUIRED WITH 5TH JAW IN 9 O'CLOCK POSITION
  - b. BOTH PHASES TO THE LINE SIDE OF THE METER BASE MUST BE ENERGIZED PRIOR TO METER INSTALLATION
  - c. NEUTRAL CONDUCTOR MUST BE BROUGHT INTO AND TERMINATED AT THE METER BASE
- ④ MAIN DISCONNECT MUST BE LOCKABLE

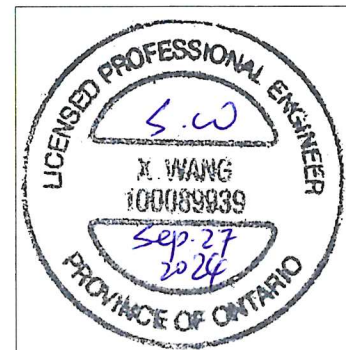

- MAINTAIN A MINIMUM 1m (39") CLEARANCE IN FRONT OF METER BASE(S) AND INSTRUMENT TRANSFORMER COMPARTMENT(S)

REV.	DESCRIPTION	DATE	INITIALS
1	STANDARD CREATED	05/30/2024	BD

**Certificate of Approval**  
 The installation work covered by this document meets the safety requirements of Section 4 of Regulation 22/04

*Shaun Wang*     *Sep. 27, 2024*  
 \_\_\_\_\_  
 Date  
*P. Eng.*  
 \_\_\_\_\_  
 Signature & Professional Designation

## TITLE: METER BASE - STANDARD MOUNTING LAYOUT FOR THREE PHASE, SECONDARY SERVICES WITH LOW-VOLTAGE SWITCHGEAR, 120/208V OR 347/600V

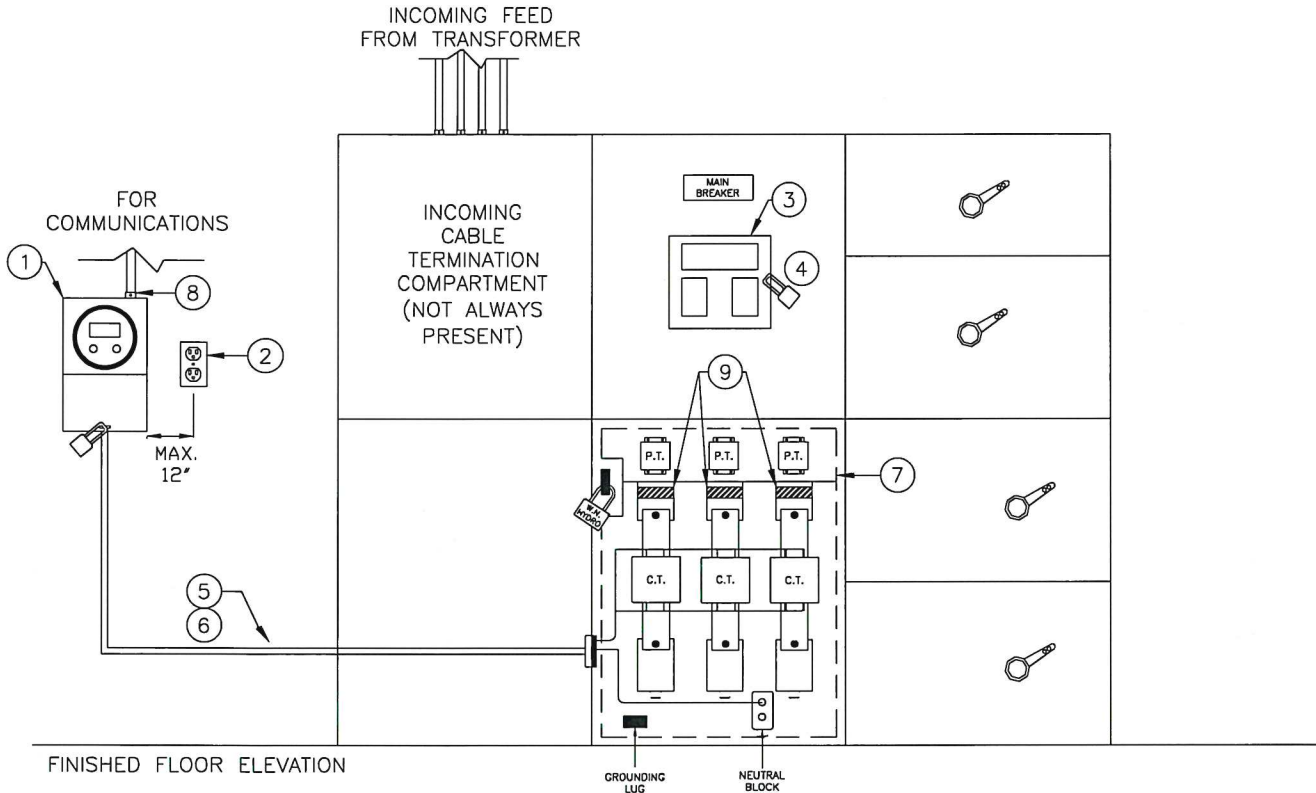

- ① 13-JAW METER BASE. METER BASE TO BE LOCATED ON GROUND LEVEL FLOOR AND MOUNTED AT 1.5m (5'0") ± 150mm (6") FROM FINISHED FLOOR ELEVATION TO CENTER OF METER. SEE APPENDIX B SELECTION TABLE FOR APPROVED METER BASES.
- ② GROUNDED 120VAC DUPLEX RECEPTACLE – FED FROM DEDICATED 15A SINGLE-POLE BREAKER, SUPPLIED & INSTALLED BY CUSTOMER'S CONTRACTOR
- ③ ALL ELECTRICAL INPUTS TO THIS EQUIPMENT MUST BE CONNECTED ON THE LOAD SIDE OF THE REVENUE METERING INSTRUMENTS, OUTSIDE OF THE METERING TRANSFORMER COMPARTMENT.
- ④ MAIN DISCONNECT MUST BE LOCKABLE
- ⑤ FUSING REQUIRED ON POTENTIAL CONDUCTORS IF CONDUCTOR LENGTH IS >3m
- ⑥ 30mm (1-1/4") EMT OR PVC CONDUIT MAXIMUM LENGTH 15m (50') OF CONDUIT—MUST BE CONTINUOUS FROM FRONT OF SWITCHGEAR INSTRUMENT TRANSFORMER COMPARTMENT TO METER BASE
- ⑦ REVENUE METERING INSTRUMENT TRANSFORMER COMPARTMENT
- ⑧ CUSTOMER CONTRACTOR TO INSTALL 30mm (1-1/4") EMT OR PVC CONDUIT FROM 13 JAW METER BASE TO A LOCKABLE 8"x8"x4" NEMA JUNCTION BOX LOCATED 1.5m (5.0") ± 150mm (6") FROM FINISHED GRADE IN AN AREA WITH GOOD CELL RECEPTION FOR COMMUNICATIONS. THIS LOCATION WILL ALSO REQUIRE A DEDICATED 120V RECEPTACLE. CONSULT WITH EPC METER DEPARTMENT PRIOR TO INSTALLATION.
- ⑨ PHASE MARKING TAPE – RED, YELLOW, BLUE (LEFT TO RIGHT)
  - ALL METERING CT'S AND PT'S TO BE LOCATED ON LOAD SIDE OF MAIN DISCONNECT
  - MAINTAIN A MINIMUM 1m (39") CLEARANCE IN FRONT OF METER BASE(S) AND INSTRUMENT TRANSFORMER COMPARTMENT(S)

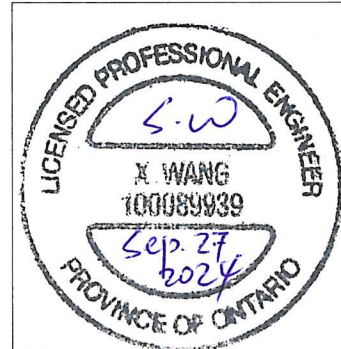

**Certificate of Approval**

The installation work covered by this document meets the safety requirements of Section 4 of Regulation 22/04

*Shaun Wang*      *Sep. 27, 2024*  
 Date

*[Signature]*      P. Eng.  
 Signature & Professional Designation

REV.	DESCRIPTION	DATE	INITIALS
1	ENOVA STANDARDS UPDATE STANDARD	02/27/2024	RO
2	ENOVA STANDARDS UPDATE STANDARD	07/12/2024	BD

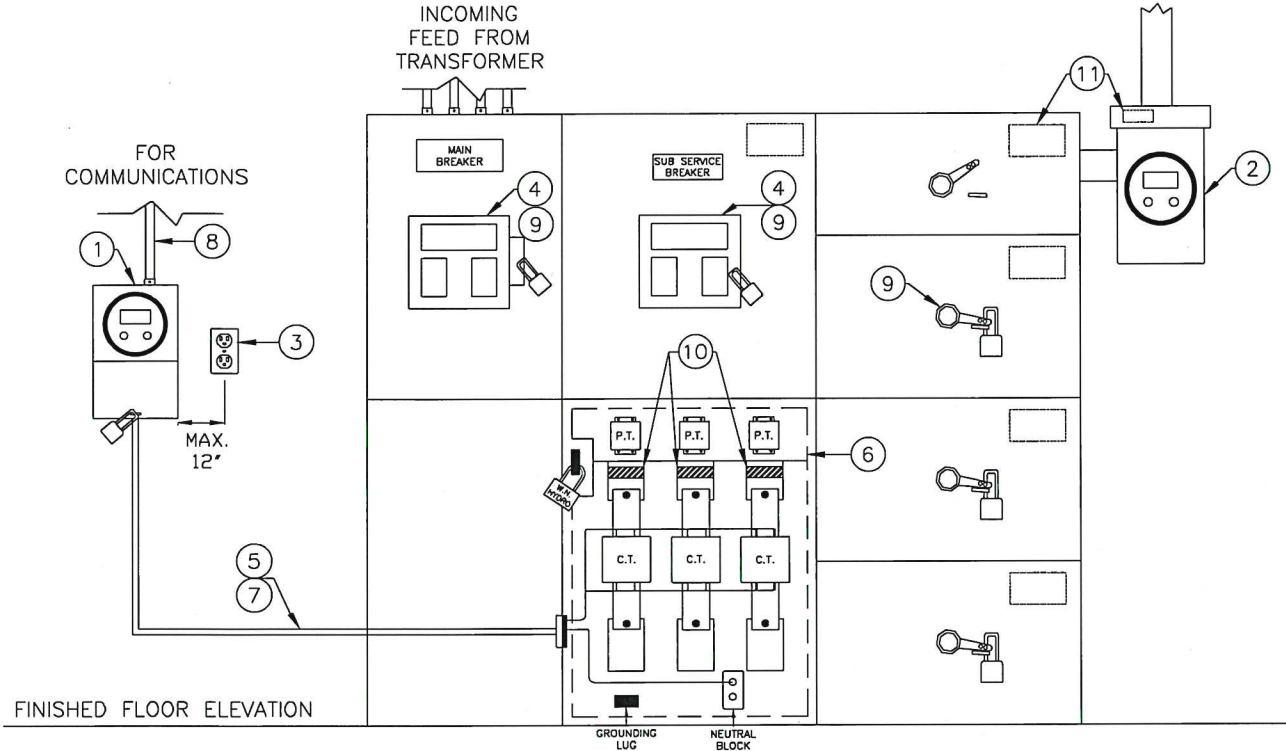
TITLE: MULTIPLE UNIT METERING, COMBINATION OF SERVICES BELOW AND ABOVE  
 225 AMPS - 120/240V, 120/208V AND 347/600V - EQUIPMENT LAYOUT

FINISHED FLOOR ELEVATION

- ① 13-JAW METER BASE. METER BASE TO BE LOCATED ON GROUND LEVEL FLOOR AND MOUNTED AT 1.5m (5'0") ± 150mm (6") FROM FINISHED FLOOR ELEVATION TO CENTER OF METER. SEE APPENDIX B SELECTION TABLE FOR APPROVED METER BASES.
- ② SUB-SERVICE METER BASES:  
SEE EPC METERING SPECIFICATION MS-20A FOR FURTHER SUB-SERVICE REQUIREMENTS.
- ③ GROUNDED 120VAC DUPLEX RECEPTACLE - FED FROM DEDICATED 15A SINGLE-POLE BREAKER, SUPPLIED & INSTALLED BY CUSTOMER'S CONTRACTOR
- ④ ALL ELECTRICAL INPUTS TO THIS EQUIPMENT MUST BE CONNECTED ON THE LOAD SIDE OF THE REVENUE METERING INSTRUMENTS, OUTSIDE OF THE METERING TRANSFORMER COMPARTMENT
- ⑤ FUSING REQUIRED ON POTENTIAL CONDUCTORS IF CONDUCTOR LENGTH IS >3m
- ⑥ REVENUE METERING INSTRUMENT TRANSFORMER COMPARTMENT
- ⑦ 30mm (1-1/4") EMT OR PVC CONDUIT MAXIMUM LENGTH 15m (50') OF CONDUIT-MUST BE CONTINUOUS FROM FRONT OF SWITCHGEAR INSTRUMENT TRANSFORMER COMPARTMENT TO METER BASE
- ⑧ CUSTOMER CONTRACTOR TO INSTALL 30mm (1-1/4") EMT OR PVC CONDUIT FROM 13 JAW METER BASE TO A LOCKABLE 8"x8"x4" NEMA JUNCTION BOX LOCATED 1.5m (5.0") ± 150mm (6") FROM FINISHED GRADE IN AN AREA WITH GOOD CELL RECEPTION FOR COMMUNICATIONS. THIS LOCATION WILL ALSO REQUIRE A DEDICATED 120V RECEPTACLE. CONSULT WITH EPC METER DEPARTMENT PRIOR TO INSTALLATION.
- ⑨ ALL DISCONNECTS MUST BE LOCKABLE
- ⑩ PHASE MARKING TAPE - RED, YELLOW, BLUE (LEFT TO RIGHT)
- ⑪ UNIT LABELING AS PER METERING SPECIFICATION MS-1
  - ALL METERING CT'S AND PT'S TO BE LOCATED ON LOAD SIDE OF MAIN DISCONNECT
  - MAINTAIN A MINIMUM 1m (39") CLEARANCE IN FRONT OF METER BASE(S) AND INSTRUMENT TRANSFORMER COMPARTMENT(S)

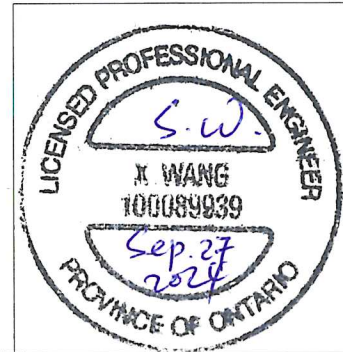

**Certificate of Approval**  
 The installation work covered by this document meets the safety requirements of Section 4 of Regulation 22/04

Signature: *Shaun Wang* Date: *Sep. 27, 2024*  
 Signature: *P. Zeng* Signature & Professional Designation

REV.	DESCRIPTION	DATE	INITIALS
1	UPDATED TO NEW DRAFTING STANDARD	03/26/2021	BD
2	ENOVA STANDARDS UPDATE STANDARD	02/22/2024	RO
3	ENOVA STANDARDS UPDATE	07/12/2024	BD

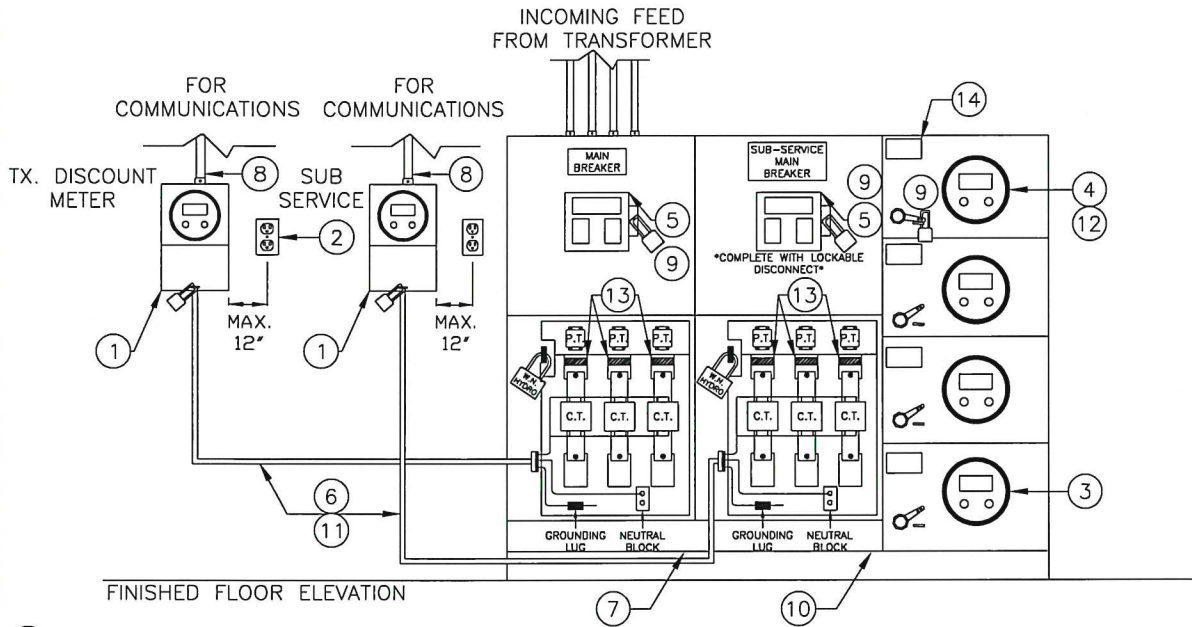

- ① 13-JAW METER BASE. METER BASE TO BE LOCATED ON GROUND LEVEL FLOOR AND MOUNTED AT 1.5m (5'0") ± 150mm (6") FROM FINISHED FLOOR ELEVATION TO CENTER OF METER. SEE APPENDIX B SELECTION TABLE FOR APPROVED METER BASES.
  - ② GROUNDED 120VAC DUPLEX RECEPTACLE - FED FROM DEDICATED 15A SINGLE-POLE BREAKER, SUPPLIED & INSTALLED BY CUSTOMER'S CONTRACTOR
  - ③ MINIMUM MOUNTING HEIGHT OF BOTTOM METER: 0.6m (24") FROM FINISHED FLOOR ELEVATION TO CENTER OF METER FACE
  - ④ MAXIMUM MOUNTING HEIGHT OF TOP METER: 1.82m (6'0") ± 150mm (6") FROM FINISHED FLOOR ELEVATION TO CENTER OF METER FACE
  - ⑤ ALL ELECTRICAL INPUTS TO THIS EQUIPMENT MUST BE CONNECTED ON THE LOAD SIDE OF THE REVENUE METERING INSTRUMENTS, OUTSIDE OF THE METERING TRANSFORMER COMPARTMENT
  - ⑥ 30mm (1-1/4") EMT OR PVC CONDUIT MAXIMUM LENGTH 15m (50') OF CONDUIT-MUST BE CONTINUOUS FROM FRONT OF SWITCHGEAR INSTRUMENT TRANSFORMER COMPARTMENT TO METER BASE
  - ⑦ SECONDARY TRANSFORMER DISCOUNT METERING COMPARTMENT (IF APPLICABLE)
  - ⑧ CUSTOMER CONTRACTOR TO INSTALL 30mm (1-1/4") EMT OR PVC CONDUIT FROM 13 JAW METER BASE TO A LOCKABLE 8"x8"x4" NEMA JUNCTION BOX LOCATED 1.5m (5.0") ± 150mm (6") FROM FINISHED GRADE IN AN AREA WITH GOOD CELL RECEPTION FOR COMMUNICATIONS. THIS LOCATION WILL ALSO REQUIRE A DEDICATED 120V RECEPTACLE. CONSULT WITH EPC METER DEPARTMENT PRIOR TO INSTALLATION.
  - ⑨ ALL DISCONNECTS MUST BE LOCKABLE
  - ⑩ REVENUE METERING INSTRUMENT TRANSFORMER COMPARTMENT
  - ⑪ FUSING REQUIRED ON POTENTIAL CONDUCTORS IF CONDUCTOR LENGTH IS >3m
  - ⑫ SUB-SERVICE METER BASES: SEE EPC METERING SPECIFICATION MS-20A FOR FURTHER SUB-SERVICE REQUIREMENTS
  - ⑬ PHASE MARKING TAPE - RED, YELLOW, BLUE (LEFT TO RIGHT)
  - ⑭ UNIT NUMBERING AS PER DRAWINGS MS-1
- ALL METERING CT'S AND PT'S TO BE LOCATED ON LOAD SIDE OF MAIN DISCONNECT
  - MAINTAIN A MINIMUM 1m (39") CLEARANCE IN FRONT OF METER BASE(S) AND INSTRUMENT TRANSFORMER COMPARTMENT(S)

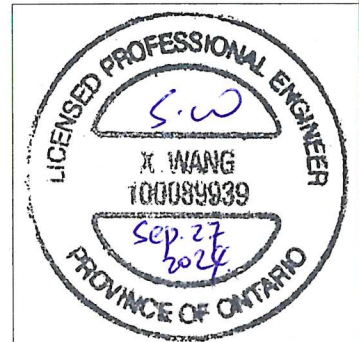
**Certificate of Approval**

The installation work covered by this document meets the safety requirements of Section 4 of Regulation 22/04

Shaun Wang

 Sep. 27, 2024  
Date

 P. Zeng  
Signature & Professional Designation

REV.	DESCRIPTION	DATE	INITIALS
1	UPDATED TO NEW DRAFTING STANDARD	03/23/2021	BD
2	ENOVA STANDARDS UPDATE STANDARD	02/22/2024	RO
3	ENOVA STANDARDS UPDATE	07/12/2024	BD

## TITLE: METER CABINET - STANDARD MOUNTING LAYOUT FOR THREE PHASE, SECONDARY SERVICES 225-800 AMPS WITHOUT SWITCHGEAR

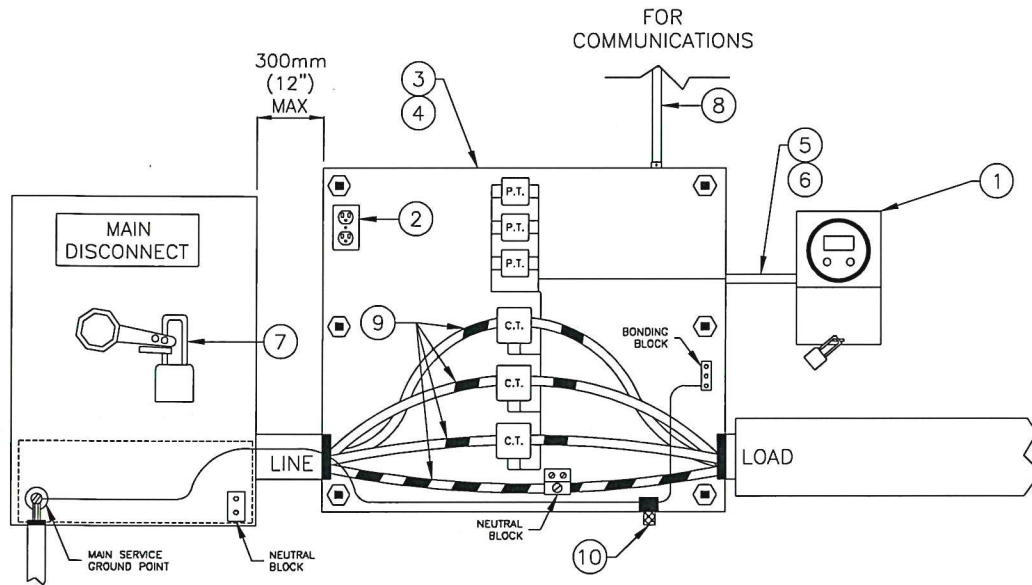

## FINISHED FLOOR ELEVATION

- ① 13-JAW METER BASE. METER BASE TO BE LOCATED ON GROUND LEVEL FLOOR AND MOUNTED AT 1.5m (5'0") ± 150mm (6") FROM FINISHED FLOOR ELEVATION TO CENTER OF METER. SEE APPENDIX B SELECTION TABLE FOR APPROVED METER BASES.
- ② GROUNDED 120VAC DUPLEX RECEPTACLE - FED FROM DEDICATED 15A SINGLE-POLE BREAKER, SUPPLIED & INSTALLED BY CUSTOMER'S CONTRACTOR
- ③ METER CABINET DIMENSIONS 900mm x 900mm x 300mm (36"x36"x12") OR ALTERNATE SIZE OF 1200mm X 1200mm X 300mm (48"x48"x12") COMPLETE WITH REMOVABLE BACK PLATE AND 2 SIDE-HINGED CENTER OPENING DOORS. CABINET TO BE MOUNTED AT A HEIGHT OF 1.83m(6') ± 50mm(2") FROM FINISHED FLOOR ELEVATION TO TOP OF CABINET. FOR OUTDOOR INSTALLATIONS, A STAINLESS STEEL NEMA 3R CABINET IS REQUIRED COMPLETE WITH A 200W HEATER (HEATER BY CUSTOMER).
- ④ METER CABINET MUST BE SECURELY FASTENED TO SUPPORTING WALL WITH AN ADEQUATE NUMBER OF PROPERLY SIZED FASTENERS TO SUPPORT A FULLY LOADED CABINET AND BACK PLATE ASSEMBLY WEIGHT OF 90KG (200LBS)
- ⑤ FUSING REQUIRED ON POTENTIAL CONDUCTORS IF CONDUCTOR LENGTH IS >3m
- ⑥ 30mm (1-1/4") EMT OR PVC CONDUIT MAXIMUM LENGTH 15m (50') OF CONDUIT-MUST BE CONTINUOUS FROM METER CABINET TO METER BASE
- ⑦ MAIN DISCONNECT MUST BE LOCKABLE
- ⑧ CUSTOMER CONTRACTOR TO INSTALL 30mm (1-1/4") EMT OR PVC CONDUIT FROM METER CABINET TO A LOCKABLE 8"x8"x4" NEMA JUNCTION BOX LOCATED 1.5m (5.0") ± 150mm (6") FROM FINISHED GRADE IN AN AREA WITH GOOD CELL RECEPTION FOR COMMUNICATIONS. THIS LOCATION WILL ALSO REQUIRE A DEDICATED 120V RECEPTACLE. CONSULT WITH EPC METER DEPARTMENT PRIOR TO INSTALLATION.
- ⑨ PHASE MARKING TAPE - RED, YELLOW, BLUE, WHITE (TOP TO BOTTOM)
- ⑩ BONDING LUG AS PER DRAWING MS-2
  - ALL METERING CT'S AND PT'S TO BE LOCATED ON LOAD SIDE OF MAIN DISCONNECT
  - MAINTAIN A MINIMUM 1m (39") CLEARANCE IN FRONT OF METER BASE(S) AND INSTRUMENT TRANSFORMER COMPARTMENT(S)

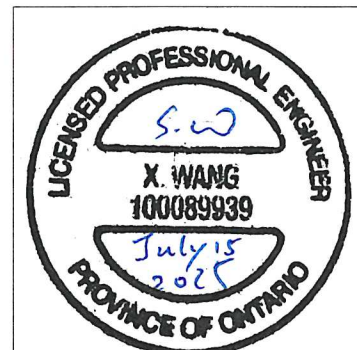

**Certificate of Approval**  
 The installation work covered by this document meets the safety requirements of Section 4 of Regulation 22/04

Signature: *Shaun Wang* Date: *July 15, 2025*  
 Signature & Professional Designation: *P. Eng.*

REV.	DESCRIPTION	DATE	INITIALS
2	ENOVA STANDARDS UPDATE STANDARD	02/22/2024	RO
3	ENOVA STANDARDS UPDATE	07/12/2024	BD
4	NOTE 3 REVISED	07/14/2025	BM

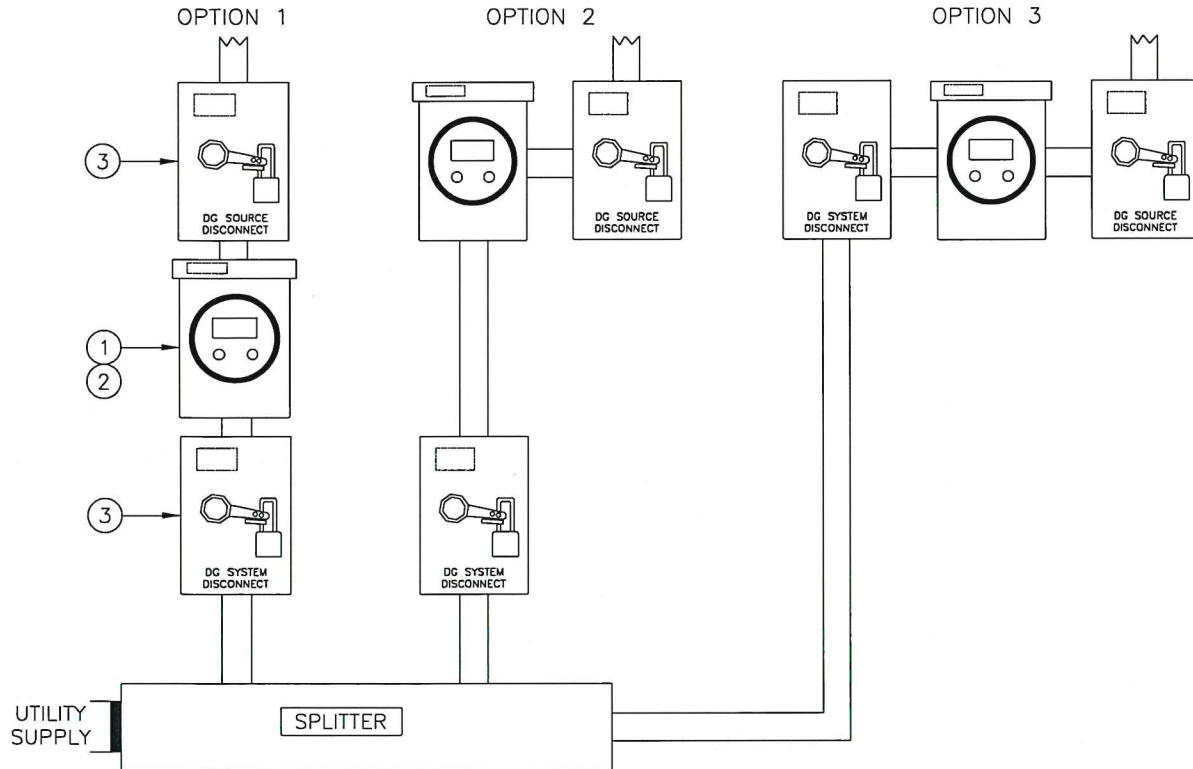

- ① CUSTOMER/CONTRACTOR TO SUPPLY AND INSTALL EPC APPROVED 7-JAW METER BASE COMPLETE WITH ISOLATED NEUTRAL BLOCK. METER BASE TO BE LOCATED ON GROUND LEVEL FLOOR AND MOUNTED AT 1.5m (5'0") ± 150mm (6") FROM FINISHED FLOOR ELEVATION TO CENTER OF METER. SEE APPENDIX B SELECTION TABLE FOR APPROVED METER BASES
- ② NEUTRAL CONDUCTOR MUST BE BROUGHT INTO AND TERMINATED IN THE METER BASE
- ③ DG SOURCE AND DG SYSTEM DISCONNECT SWITCHES MUST BE LOCKABLE AND ARE TO BE LOCATED INSIDE THE SAME ELECTRICAL ROOM AND VISIBLE FROM GENERATION METER

- MAINTAIN A MINIMUM 1m (39") CLEARANCE IN FRONT OF METER BASE(S) AND INSTRUMENT TRANSFORMER COMPARTMENT(S)

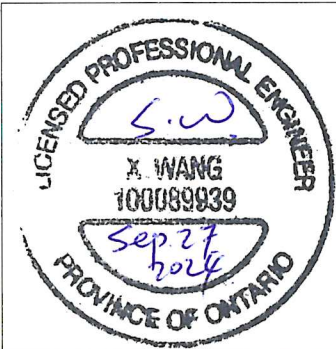

**Certificate of Approval**

The installation work covered by this document meets the safety requirements of Section 4 of Regulation 22/04

 Shaun Wang Sep 27 2024  
 Date

 P. Zeng  
 Signature & Professional Designation

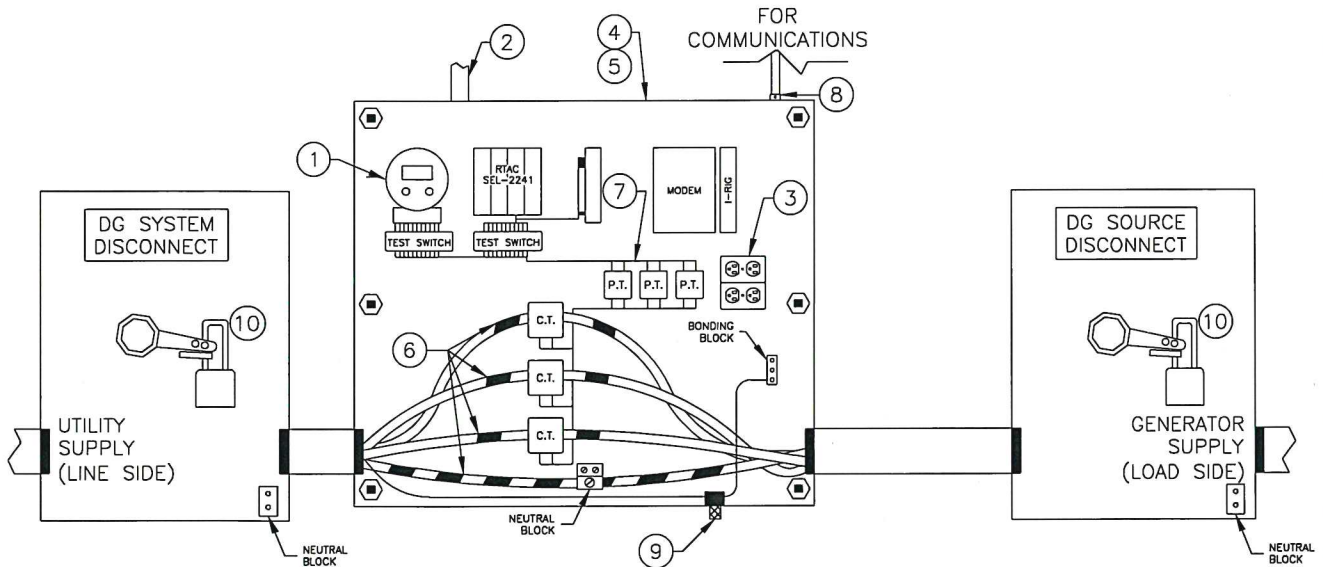
REV.	DESCRIPTION	DATE	INITIALS
1	UPDATED TO NEW DRAFTING STANDARD	03/23/2021	BD
2	ENOVA STANDARDS UPDATE STANDARD	02/22/2024	RO
3	ENOVA STANDARDS UPDATE	07/26/2024	BD



- ① METER BASE ADAPTER TO BE PROVIDED BY EPC.
- ② 63.5mm (2-1/2") CONTINUOUS CONDUIT, COMPLETE WITH PULL ROPE, IN A STRAIGHT LINE FROM THE METERING CABINET TO THE ROOF FOR FUTURE SCADA ANTENNA.
- ③ GROUNDED 2 GANG 120VAC DUPLEX RECEPTACLES – FED FROM DEDICATED 15A SINGLE-POLE BREAKER, SUPPLIED & INSTALLED BY CUSTOMER'S CONTRACTOR
- ④ METER CABINET DIMENSIONS 1200mm X 1200mm X 300mm (48"x48"x12") COMPLETE WITH REMOVABLE BACK PLATE AND 2 SIDE-HINGED CENTER OPENING DOORS SUPPLIED BY CUSTOMER. CABINET TO BE MOUNTED AT A HEIGHT OF 1.83m (6') ± 50mm (2") FROM FINISHED FLOOR ELEVATION TO TOP OF CABINET. STAINLESS STEEL NEMA 3R CABINET REQUIRED FOR OUTDOOR INSTALLATIONS
- ⑤ METER CABINET MUST BE SECURELY FASTENED TO SUPPORTING WALL WITH AN ADEQUATE NUMBER OF PROPERLY SIZED FASTENERS TO SUPPORT A FULLY LOADED CABINET AND BACK PLATE ASSEMBLY WEIGHT OF 90KG (200LBS)
- ⑥ PHASE MARKING TAPE – RED, YELLOW, BLUE, WHITE (TOP TO BOTTOM)
- ⑦ PT'S ONLY REQUIRED FOR 347/600V SERVICES
- ⑧ CUSTOMER CONTRACTOR TO INSTALL 30mm (1-1/4") EMT OR PVC CONDUIT FROM METER CABINET TO A LOCKABLE 8"x8"x4" NEMA JUNCTION BOX LOCATED 1.5m (5.0") ± 150mm (6") FROM FINISHED GRADE IN AN AREA WITH GOOD CELL RECEPTION FOR COMMUNICATIONS. THIS LOCATION WILL ALSO REQUIRE A DEDICATED 120V RECEPTACLE. CONSULT WITH EPC METER DEPARTMENT PRIOR TO INSTALLATION.
- ⑨ BONDING LUG AS PER DRAWING MS-2
- ⑩ DG SOURCE AND DG SYSTEM DISCONNECT SWITCHES MUST BE LOCKABLE AND ARE TO BE LOCATED INSIDE THE SAME ELECTRICAL ROOM AND VISIBLE FROM THE GENERATION METER

- NO SERVICE CONDUCTORS PERMITTED ABOVE CT'S
- ALL METERING CT'S AND PT'S TO BE LOCATED ON LOAD SIDE OF MAIN DISCONNECT
- MAINTAIN A MINIMUM 1m (39") CLEARANCE IN FRONT OF METER BASE(S) AND INSTRUMENT TRANSFORMER COMPARTMENT(S)

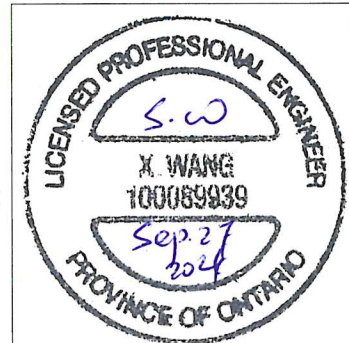

**Certificate of Approval**  
 The installation work covered by this document meets the safety requirements of Section 4 of Regulation 22/04

Shawn Wang *Signature* Sep 27 2024 *Date*  
 P. Eng. *Signature*  
 Signature & Professional Designation

REV.	DESCRIPTION	DATE	INITIALS
1	UPDATED TO NEW DRAFTING STANDARD	03/23/2021	BD
2	ENOVA STANDARDS UPDATE STANDARD	02/22/2024	RO
3	ENOVA STANDARDS UPDATE	07/09/2024	BD

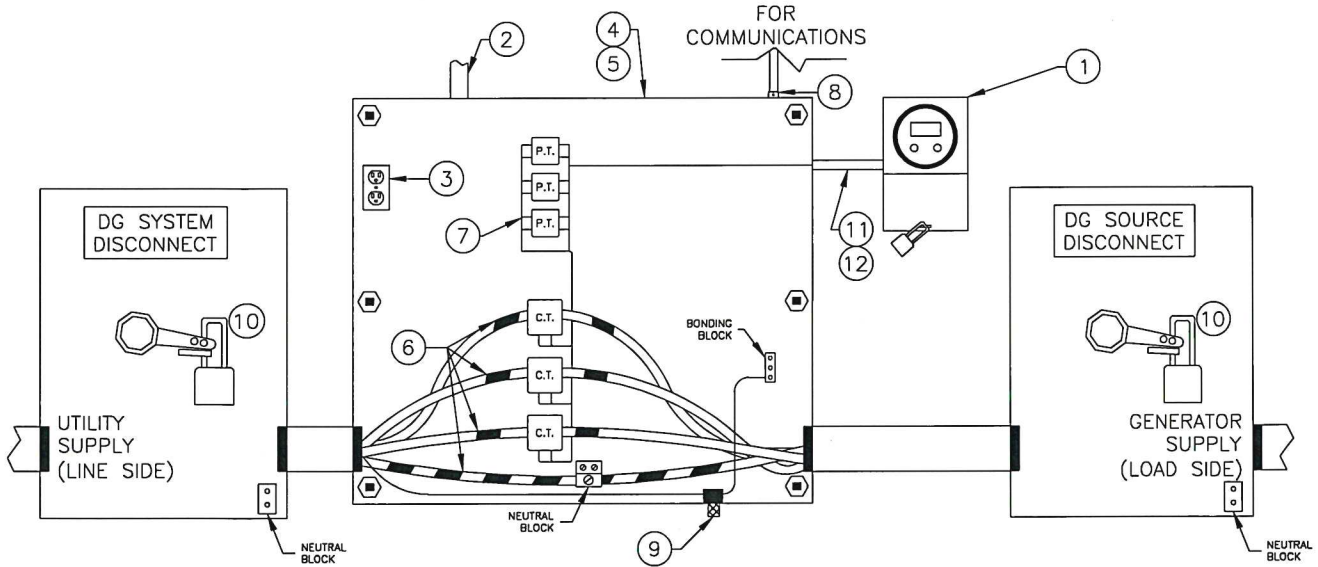

- ① 13-JAW METER BASE. METER BASE TO BE LOCATED ON GROUND LEVEL FLOOR AND MOUNTED AT 1.5m (5'0") ± 150mm (6") FROM FINISHED FLOOR ELEVATION TO CENTER OF METER. SEE APPENDIX B SELECTION TABLE FOR APPROVED METER BASES.
- ② 63.5mm (2-1/2") CONTINUOUS CONDUIT, COMPLETE WITH PULL ROPE, IN A STRAIGHT LINE FROM THE METERING CABINET TO THE ROOF FOR FUTURE SCADA ANTENNA.
- ③ GROUNDED 120VAC DUPLEX RECEPTACLE - FED FROM DEDICATED 15A SINGLE-POLE BREAKER, SUPPLIED & INSTALLED BY CUSTOMER'S CONTRACTOR
- ④ METER CABINET DIMENSIONS 1200mm X 1200mm X 300mm (48"x48"x12") COMPLETE WITH REMOVABLE BACK PLATE AND 2 SIDE-HINGED CENTER OPENING DOORS SUPPLIED BY CUSTOMER. CABINET TO BE MOUNTED AT A HEIGHT OF 1.83m (6') ± 50mm (2") FROM FINISHED FLOOR ELEVATION TO TOP OF CABINET. STAINLESS STEEL NEMA 3R CABINET REQUIRED FOR OUTDOOR INSTALLATIONS
- ⑤ METER CABINET MUST BE SECURELY FASTENED TO SUPPORTING WALL WITH AN ADEQUATE NUMBER OF PROPERLY SIZED FASTENERS TO SUPPORT A FULLY LOADED CABINET AND BACK PLATE ASSEMBLY WEIGHT OF 90KG (200LBS)
- ⑥ PHASE MARKING TAPE - RED, YELLOW, BLUE, WHITE (TOP TO BOTTOM)
- ⑦ PT'S ONLY REQUIRED FOR 347/600V SERVICES
- ⑧ CUSTOMER CONTRACTOR TO INSTALL 30mm (1-1/4") EMT OR PVC CONDUIT FROM METER CABINET TO A LOCKABLE 8"x8"x4" NEMA JUNCTION BOX LOCATED 1.5m (5.0") ± 150mm (6") FROM FINISHED GRADE IN AN AREA WITH GOOD CELL RECEPTION FOR COMMUNICATIONS. THIS LOCATION WILL ALSO REQUIRE A DEDICATED 120V RECEPTACLE. CONSULT WITH EPC METER DEPARTMENT PRIOR TO INSTALLATION.
- ⑨ BONDING LUG AS PER DRAWING MS-2
- ⑩ DG SOURCE AND DG SYSTEM DISCONNECT SWITCHES MUST BE LOCKABLE AND ARE TO BE LOCATED INSIDE THE SAME ELECTRICAL ROOM AND VISIBLE FROM THE GENERATION METER
- ⑪ 30mm (1-1/4") EMT OR PVC CONDUIT MAXIMUM LENGTH 15m (50') OF CONDUIT-MUST BE CONTINUOUS FROM METER CABINET TO METER BASE
- ⑫ FUSING REQUIRED ON POTENTIAL CONDUCTORS IF CONDUCTOR LENGTH IS >3m

- NO SERVICE CONDUCTORS PERMITTED ABOVE CT'S
- ALL METERING CT'S AND PT'S TO BE LOCATED ON LOAD SIDE OF MAIN DISCONNECT
- MAINTAIN A MINIMUM 1m (39") CLEARANCE IN FRONT OF METER BASE(S) AND INSTRUMENT TRANSFORMER COMPARTMENT(S)

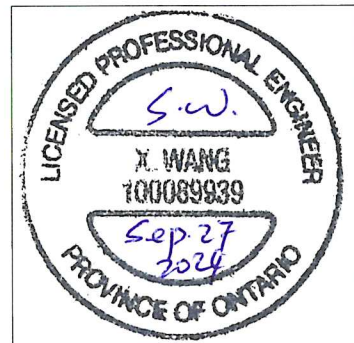

**Certificate of Approval**  
 The installation work covered by this document meets the safety requirements of Section 4 of Regulation 22/04

Shawn Wang Sep 27 2024  
 Date

P. Eng.  
 Signature & Professional Designation

REV.	DESCRIPTION	DATE	INITIALS
0	STANDARD CREATED	07/26/2024	BD

## **Appendix 'B'**

# **EPC Approved Meter Bases**

**Enova reserves the right to update this Appendix. Contact Enova for the most updated list prior to ordering.**



DATE:  
2026-01-09

SCALE:  
NTS

REV.  
6

DWG. NO.  
**APPENDIX B**

TITLE: **EPC APPROVED METER BASES**

**SINGLE POSITION METER BASE SELECTION TABLE**

SERVICE VOLT-GE (PH-SE/WIRE)	SERVICE -MPER-GE	SOCKET TYPE	-NSI FORM TYPE	-PPROVED MODELS
120/240V (1PH 3W) UNDERGROUND SERVICE	<= 200-	4 J-W	FORM 2S	<u>MICROELECTRIC</u> : BS2-TCV, BS2-TV, BS2-TCVF- <u>HYDEL</u> : EK400R0, EK400T0 <u>E-TON</u> : LM2, LU2
120/240V (1PH 3W) OVERHE-D SERVICE	<= 200-	4 J-W	FORM 2S	-NY 200- CS- -PPROVED MODEL
120/240V (1PH 3W)	400-	5 J-W (NOTES 1,2)	FORM 3S	HYDEL - CT4 (CT SUPPLIED BY ENOV-) E-TON - TCC5 (CT SUPPLIED BY ENOV-)
120/240V CENTR-L METERED SERVICE (1PH 3W)	<=600-	5 J-W (NOTES 1,2)	FORM 3S	<u>MICROELECTRIC</u> : CL5-V <u>HYDEL</u> : CTS409PW <u>E-TON</u> : TCC5-0
120/208V NETWORK SERVICE (2PH 3W)	<=200-	5 J-W (NOTE 1)	FORM 12S	-NY CS- -PPROVED MODEL
120/208V (3PH 4W)	<=200-	7 J-W	FORM 16S	-NY CS- -PPROVED MODEL
347/600V (3PH 4W)	<=200-	7 J-W	FORM 16S	-NY CS- -PPROVED MODEL
120/208V OR 347/600V (3PH 4W)	>200-	13 J-W	FORM 9S	<u>E-TON</u> : TSU13 <u>HYDEL</u> : CTS130PW <u>MICROELECTRIC</u> : CT113

**MULTI POSITION METER BASE SELECTION TABLE**

SERVICE VOLT-GE (PH-SE/WIRE)	SERVICE -MPER-GE	SOCKET TYPE	-NSI Form Type	-PPROVED MODELS
120/240V (1PH 3W) UNDERGROUND SERVICE	<=200- PER POSITION	4 J-W (NOTES 3,4)	FORM 2S	<u>MICROELECTRIC</u> : BD-2-V <u>E-TON</u> : 2K2, 3K2, 2K4, 3K4 <u>HYDEL</u> : HC22R, HC23R, HC42R, HC43R
120/240V (1PH 3W) OVERHE-D SERVICE	<=200- PER POSITION	4 J-W	FORM 2S	-NY CS- -PPROVED MODEL

**OESC REQUIRED ISOLATED NEUTRAL**

AS PER THE LATEST REVISION OF ESA BULLETIN 10-15-\*, SINGLE GANG METER BASES SHALL INCLUDE AN ISOLATED NEUTRAL TERMINAL BLOCK WHEN THE CONSUMER SERVICE IS GROUNDED AT THE SERVICE BOX.  
METER BASE MODELS IN THIS TABLE SHALL BE ORDERED WITH THE APPROPRIATE SUFFIX OR KIT TO COMPLY WITH ALL OESC REQUIREMENTS.

- ① 5TH JAW REQUIRED IN THE 9'O'CLOCK POSITION.
- ② BY-PASS DEVICE REQUIRED ON LEFT SIDE JAWS.
- ③ MAXIMUM NUMBER OF METER BASE POSITIONS FOR AN UNDERGROUND SERVICE IS THREE.
- ④ ALL UNDERGROUND SERVICE MULTIPLE POSITION METER BASES REQUIRE A BLANK CONNECTION COMPARTMENT WITH PROVISION FOR AN EXTERNAL PADLOCK.

REV.	DESCRIPTION	DATE	INITIALS
2	ENOVA STANDARDS UPDATE STANDARD	02/22/2024	RO
3	ENOVA STANDARDS UPDATE STANDARD	09/16/2024	BD
4	ADD BS2-TCVFA TO 120/240V (1PH 3W) UNDERGROUND SERVICE	06/13/2025	BD
5	ADDED ISOLATED NEUTRAL NOTE	11/07/2025	BM
6	ADDED TCC5-0	01/09/2026	BM

# **Appendix 'C'**

## **EPC Approved Combination Transfer Switch Meter Bases & Plug-In Transfer Devices**

**Enova reserves the right to update this Appendix. Contact Enova for the most updated list prior to ordering.**



DATE:  
2024-08-19

SCALE:  
NTS

REV.  
2

DWG. NO.  
**APPENDIX C**

TITLE: **EPC APPROVED COMBINATION TRANSFER SWITCH METER BASES & PLUG-IN TRANSFER DEVICES**

**COMBINATION TRANSFER SWITCH METER BASES (SECTION 3.8.16)**

SERVICE VOLTAGE (PHASE/WIRE)	SERVICE AMPERAGE	SOCKET TYPE	ANSI FORM TYPE	APPROVED MODELS
120/240V (1PH 3W)	<=200A	4 JAW	FORM 2S	<u>EATON</u> : EGSC200AMSE

**PLUG IN TRANSFER DEVICES (SECTION 3.8.15)**

SERVICE VOLTAGE (PHASE/WIRE)	SERVICE AMPERAGE	SOCKET TYPE	ANSI FORM TYPE	APPROVED MODELS
120/240V (1PH 3W)	<=200A	4 JAW	FORM 2S	<u>GENERLINK</u> : MA23-N, MA23-S, MA24-N, MA24-S

REV.	DESCRIPTION	DATE	INITIALS
1	APPENDIX C CREATED	03/24/2021	BD
2	UPDATED FROM WNH TO EPC	08/19/2024	BD

# **Appendix 'D' Metering Pulse Output(s) Access Agreement**

## Metering Pulse Output(s) Agreement

This agreement between

Enova Power Corp  
301 Victoria Street South Kitchener, Ontario, N2M 3A2  
526 Country Squire Rd Waterloo, Ontario N2J 4G8

hereafter referred to as Enova

and

Customer's Business Name: \_\_\_\_\_

Address: \_\_\_\_\_

City: \_\_\_\_\_ Province/State: \_\_\_\_\_

Postal/Zip Code: \_\_\_\_\_

carrying out business at

Customer's Service Address: \_\_\_\_\_

City: \_\_\_\_\_ Province: \_\_\_\_\_

Postal Code: \_\_\_\_\_

ENOVA. Account #: \_\_\_\_\_

carrying out business as

Business Name: \_\_\_\_\_

hereafter referred to as the Customer,

Enova shall define the relationship between Enova and the Customer and its Assigned Third Party, if applicable, with respect to the provision of isolated, KYZ metering pulse output(s). For the purposes of this agreement, the term 'Assigned Third Party' is meant to include Energy Retailers, Meter Data Management Companies or Sub-Metering Providers as the case may be.

Pursuant to Section 11.1 (Provision of Current Usage Data to Retailers) and Section 11.2 (Provision of Current Usage Data to Customers) of the Retail Settlement Code, Enova agrees to provide isolated, KYZ metering pulse output(s) from Enova's meter at the Customer's above-noted service address under the following conditions:

- The Customer and Assigned Third Party accept that the availability of KYZ metering pulse output(s) is subject to termination with notice by ENOVA where practicable due to the planned elimination of this technology. Where the purchase of special meter(s) is necessary to accommodate the Customer or Third Party's requirements the Customer will bear all reasonable related costs.
- The Customer or Assigned Third Party must request a quotation for the total cost of installing equipment to provide the necessary KYZ pulses. This will include but is not limited to labour, truck time, terminal strips, and wiring. A purchase order must be issued before Enova schedules the work. Please allow 6-8 weeks after receipt of the purchase order for work to be completed due to labour scheduling and material lead times.
- Enova will supply either: Watt-hour, Watt-hour/VA-hour or Watt-hour/VAR-hour KYZ pulses depending on the outputs available from the Enova meter already installed or to be installed at the Customer's metering installation.
- If it is deemed that Enova's metering installation is somehow compromised by any unforeseen event or circumstances not present at this time, the Customer's and/or Third Party's access to the isolated, KYZ metering pulse outputs may be suspended by Enova.
- The Customer shall pay for all software, hardware or other services required for the Customer or Assigned Third Party to obtain isolated, KYZ metering pulse output access to the Enova meter.
- The Customer shall bear any cost incurred by Enova to correct problems caused by the Customer's/Assigned Third Party's access to the isolated, KYZ metering pulse output(s). This includes but is not limited to: trouble calls to repair/maintain the isolated, metering pulse output(s) connections and equipment, replacement of any parts/equipment required to sustain the metering pulse output(s), and additional labour required to re-connect and test the isolated, metering pulse output(s) during a required meter change.
- If the Customer assigns his or her right to isolated, KYZ metering pulse output(s) access to any Assigned Third Party, the Customer shall remain responsible for the action of the Assigned Third Party. Also, the Customer must supply the following contact information regarding the Assigned Third Party to Enova in the space below:

(If applicable, please complete. For more than one Assigned Third Party please attach additional information for each to the end of this Agreement.)

## Assigned Third Party Information

Business Name: \_\_\_\_\_

Contact Name: \_\_\_\_\_

Address: \_\_\_\_\_

City: \_\_\_\_\_ Province/State: \_\_\_\_\_

Postal/Zip Code: \_\_\_\_\_ Retailer License #: \_\_\_\_\_

Phone: \_\_\_\_\_ Fax: \_\_\_\_\_

E-mail: \_\_\_\_\_

- If the Customer wishes to withdraw the right from any Assigned Third Party, it must do so in writing to Enova so that any other affected parties can be notified.
- The data obtained by the Customer or its Assigned Third Party via the isolated KYZ metering pulse output(s) from the meter is to be considered raw and without any additional validation, estimation or editing applied to it by Enova. As such, it is expected that this data may vary occasionally from that supplied by Enova's billing system, or any other source of settlement-ready interval metering data. If a discrepancy occurs between any data presented to the Customer and that presented by Enova's actual billing, Enova's actual billing must be used as correct values. Enova does not assume any liability for any damages or losses that may occur as a result of further use of raw interval data.

This agreement shall be applicable to all successors and assigns and shall not be re-assigned without written notification of Enova.

Contact with the Customer regarding this agreement will be with the person(s) listed below with respect to this interval metering installation for the purposes of read-only access. The Primary Contact will maintain the communication link at the interval meter location.

## Customer Contact Information

(Required) Primary Contact Name: \_\_\_\_\_

Address: \_\_\_\_\_

City: \_\_\_\_\_ Province/State: \_\_\_\_\_

Postal/Zip Code: \_\_\_\_\_ Retailer License #: \_\_\_\_\_

Phone: \_\_\_\_\_ Fax: \_\_\_\_\_

E-mail: \_\_\_\_\_

(Optional) Alternate Contact Name: \_\_\_\_\_

Address: \_\_\_\_\_

City: \_\_\_\_\_ Province/State: \_\_\_\_\_

Postal/Zip Code: \_\_\_\_\_ Retailer License #: \_\_\_\_\_

Phone: \_\_\_\_\_ Fax: \_\_\_\_\_

E-mail: \_\_\_\_\_

For the Customer, I have the authority to bind the company.

Signature: \_\_\_\_\_

Name: \_\_\_\_\_

Position: \_\_\_\_\_

Date: \_\_\_\_\_

Address: \_\_\_\_\_

City: \_\_\_\_\_ Province/State: \_\_\_\_\_

Postal/Zip Code: \_\_\_\_\_

Phone: \_\_\_\_\_ Fax: \_\_\_\_\_

E-mail: \_\_\_\_\_

Contact for Enova Power Corp. will be:

Name: Nick Hansen  
Metering Supervisor  
Phone: 226-896-2200 ext:6273 Fax:  
E-mail: [nick.hansen@enovapower.com](mailto:nick.hansen@enovapower.com)

Once the completed and signed Agreement is emailed to Enova, we will supply a detailed summary of the metering information required to enable the Customer and/or Assigned Third Party to have isolated access to this metering installation.