

## APPENDIX A2:

# TECHNICAL REQUIREMENTS FOR DISTRIBUTED GENERATORS > 12 KW TO BE CONNECTED TO ENOVA'S DISTRIBUTION SYSTEM

---

## INTRODUCTION

This document outlines the technical requirements for distributed generator/s (DG) to be connected to Enova's distribution system. It is intended to guide the DG proponent in connecting distributed generators into Enova's distribution system. The purpose of this document is to ensure public safety, protect Enova's system and employees and maintain reliable service to all Enova's customers while connecting the distributed generators. This document doesn't contain all details in designing and protecting the generation system. The DG proponent shall ensure the safety of its own facilities.

This document applies only to the distributed generation facilities larger than 12kW. The micro generation facility ( $\leq 12\text{KW}$ ) is subject to a simplified connection process with simpler connection requirements, please check Enova website for customer package **"Customer Information - How to connect your embedded generator to the grid (less than 12kW)"**

This document is for guidance purpose only. Enova does not accept any responsibility or liability for any of the information provided in this document, and meeting these requirements does not necessarily guarantee an acceptable design. Enova reserves the right to amend these requirements at any time.

## REFERENCE

OEB	Ontario Energy Board – Distribution System Code (DSC)
Ontario Regulation	Ontario Electric Safety Code (OESC)
CSA C22.3 No.9	Interconnection of Distributed Resources and Electricity Supply Systems
IEEE 1547	IEEE Standard for Interconnecting Distributed Resources with Electric Power Systems
IEEE 1547.1	Standard Conformance Test Procedures for Equipment Interconnecting Distributed Resources with Electric Power Systems
IEEE 1547.2	IEEE Application Guide for IEEE Std 1547, Interconnecting Distributed Resources with Electric Power Systems
CSA CAN3-C235	Preferred Voltage Levels for AC Systems, 0 to 50,000kV
Hydro One Networks	Distributed Generation Technical Interconnection Requirements (HydroOne TIR)
NPCC D12	Northeast Power Coordinating Council, Regional Reliability

	Reference Directory #12 – Under frequency Load Shedding Program Requirements
IEEE 1453	IEEE Recommended Practice for Measurement and Limits of Voltage Fluctuations and Associated Light Flicker on AC Power Systems
IEEE C37.119	IEEE Guide for Breaker Failure Protection of Power Circuit Breakers

## TECHNICAL REQUIREMENTS FOR DG INTERCONNECTION

In line with the Ontario Distribution System Code, IEEE 1547 and CSA No.C22.3 No.9, Enova will review and ensure the DG interconnection requirements at the following 3 stages before final connection.

- Stage of Preliminary Review
- Stage of Connection Impact Assessment
- Stage of Design Review

Additional power quality requirements apply after the DG is in service.

### 1. STAGE OF PRELIMINARY REVIEW

In the very early stage when a DG proponent is considering the site selection and planning, Enova will conduct a simple project review via PCIR based on the limited parameters provided by the DG proponent and high-level distribution system information. The purpose of the preliminary review is to quickly screen some apparently infeasible projects by using some highly simplified rules. The preliminary review does not guarantee the viability of the proposed DG project.

A Customer or developer interested in connecting a Generation Project should review the Restricted Feeders list on Enova website to determine whether the proposed connection point is located on a restricted feeder. The Restricted Feeders document is updated by Enova at least every three (3) months. It should be noted that a restricted feeder does not necessarily mean that connection is not possible. Rather, it indicates that the feeder has limited capacity to accommodate additional generation. In such cases, distribution system upgrades may be required prior to connection, and the associated costs would be the responsibility of the Customer.

#### - Preliminary Review Criteria

Enova is committed to working with the DG proponent on the preliminary review. All existing connected DG projects and all committed DG projects will be included into consideration following the criteria in Table 1. It is advised that these capacity limits might be superseded under special circumstances, and a special engineering review by Enova will be required before approval. The preliminary review process may be amended to be in line with the directions from Ontario Energy Board and Ontario Power Authority when required.

**Table 1: Preliminary Review Criteria by Enova**

Criteria				Reference														
<p><b>1.1 Capacity Limits – Transformer/Distribution Station</b></p> <p>Subject to the thermal load limit of other station equipment Enova will limit DG connected to each station following the criteria:</p>				<p>Enova requirements</p> <p>HydroOne TIR</p>														
<table border="1"> <thead> <tr> <th>Nominal Station Secondary Voltage (PP/PG)</th> <th>Max. Allowable Aggregate Capacity on Station Transformer</th> <th>Max. Allowable Aggregate Capacity on Station Bus</th> </tr> </thead> <tbody> <tr> <td>27.6/16 kV</td> <td rowspan="3">60% nameplate rating of station transformer for normal 2-winding station transformer. No reverse flow is allowed for dual secondary winding station transformer due to overheating.</td> <td rowspan="3">60% nameplate rating of station transformer + min station bus load for normal 2-winding transformer;  Min bus load for dual secondary winding transformer.</td> </tr> <tr> <td>13.8/8 kV</td> </tr> <tr> <td>8.32/4.8 kV</td> </tr> </tbody> </table>	Nominal Station Secondary Voltage (PP/PG)	Max. Allowable Aggregate Capacity on Station Transformer	Max. Allowable Aggregate Capacity on Station Bus		27.6/16 kV	60% nameplate rating of station transformer for normal 2-winding station transformer. No reverse flow is allowed for dual secondary winding station transformer due to overheating.	60% nameplate rating of station transformer + min station bus load for normal 2-winding transformer;  Min bus load for dual secondary winding transformer.	13.8/8 kV	8.32/4.8 kV									
Nominal Station Secondary Voltage (PP/PG)	Max. Allowable Aggregate Capacity on Station Transformer	Max. Allowable Aggregate Capacity on Station Bus																
27.6/16 kV	60% nameplate rating of station transformer for normal 2-winding station transformer. No reverse flow is allowed for dual secondary winding station transformer due to overheating.	60% nameplate rating of station transformer + min station bus load for normal 2-winding transformer;  Min bus load for dual secondary winding transformer.																
13.8/8 kV																		
8.32/4.8 kV																		
<p><b>1.2 Capacity Limits – Distribution Feeder</b></p> <p>Subject to the thermal loading limit of other distribution equipment, Enova will limit DG connected to each feeder following the criteria:</p>				<p>Enova requirements</p> <p>HydroOne TIR</p>														
<table border="1"> <thead> <tr> <th>Nominal Feeder Voltage (PP/PG)</th> <th>Feeder Max. Allowable 1-Phase Unit Capacity</th> <th>Feeder Max. Allowable 3-Phase Unit Capacity</th> <th>Feeder Max. Allowable Aggregate Capacity</th> </tr> </thead> <tbody> <tr> <td>27.6/16 kV</td> <td>100kW</td> <td>10MW</td> <td>13.6MW*</td> </tr> <tr> <td>13.8/8 kV</td> <td>100kW</td> <td>5MW</td> <td>6.8MW*</td> </tr> <tr> <td>8.32/4.8 kV</td> <td>100kW</td> <td>0.5MW</td> <td>1.9MW*</td> </tr> </tbody> </table>	Nominal Feeder Voltage (PP/PG)	Feeder Max. Allowable 1-Phase Unit Capacity	Feeder Max. Allowable 3-Phase Unit Capacity		Feeder Max. Allowable Aggregate Capacity	27.6/16 kV	100kW	10MW	13.6MW*	13.8/8 kV	100kW	5MW	6.8MW*	8.32/4.8 kV	100kW	0.5MW	1.9MW*	
Nominal Feeder Voltage (PP/PG)	Feeder Max. Allowable 1-Phase Unit Capacity	Feeder Max. Allowable 3-Phase Unit Capacity	Feeder Max. Allowable Aggregate Capacity															
27.6/16 kV	100kW	10MW	13.6MW*															
13.8/8 kV	100kW	5MW	6.8MW*															
8.32/4.8 kV	100kW	0.5MW	1.9MW*															
<p>*Based on Thermal Capacity at feeder. Short Circuit capacity may limit it further.</p>																		

**2. STAGE OF CONNECTION IMPACT ASSESSMENT (CIA)**

After DG proponent decides the site location and develops a project plan, Enova will

conduct the connection impact assessment to determine what adverse impact the proposed DG may have on Enova's Distribution System with regard to voltage fluctuation, fault contribution, equipment thermal loading etc. The purpose of the CIA is to determine the viability of the proposed DG project and all necessary upgrades at both Enova's System and the DG site to mitigate the adverse impact on Enova's System. The connection impact assessment does not consider the system impact on the proposed DG equipment.

#### **- Document Submission Requirements for CIA**

To conduct the Connection Impact Assessment, the DG proponent shall submit Enova the following:

- A copy of completed Connection Impact Assessment (CIA) Application sealed by a P.Eng.
- High-level single line diagrams showing the line conductor sizes and distance from the generation interface transformer to the Enova's distribution system sealed by a P.Eng;
- If applicable, provide Inverter specification along with CSA compliance certificate;
- Technical description of the operating philosophy of the electrical equipment, protection and control philosophy of the generation system and interconnection device. The application form and all above technical documents shall be signed and sealed by a licensed Ontario Professional Engineer. Enova may have additional requirements for CIA and will clarify when signing the Connection Impact Study Agreement.

#### **- Impact Assessment Criteria**

Enova will conduct the connection impact assessment using the criteria in Table 2. All existing connected DG projects and all committed DG projects with signed Connection Cost Agreements will be considered in the impact assessment.

**Table 2: Connection Impact Assessment Criteria by Enova**

Criteria	Reference
<p><b>2.1 HV and LV Isolation device at the Point of Connection</b></p> <p>The DG proponent shall provide a means of isolation at the Point of Connection in compliance with the OESC. The isolation device shall be readily accessible by Enova staff, lockable, and with visible break. The Point of Connection, normally at the HV tap of the connected distribution feeder, will be clarified by Enova at early stage.</p>	<p>DSC 4.5.2, Appendix F.2-1, 1 OESC rule 84-024, 84-026 CSA C22.3 No.9-08 rule 7.3.1 IEEE 1547 Item 4.1.7 HydroOne TIR</p>
<p><b>2.2 Interconnection Grounding Transformer (DGIT) and HV Interrupting Device</b></p> <p>The generator facilities and the associated interconnection transformer(s) shall comply with section 2.1.12 (interconnection transformer configuration) of the HydroOne TIR. The interconnection grounding shall not cause overvoltage or fault current exceeding the rating of Enova's distribution equipment. For wind generation facility, the grounding of wind towers shall not connect to the distribution system neutral. Enova will review each interconnection individually to accommodate the local system restraints and the DG manufacturer's recommendations.</p>	<p>DSC Appendix F.2 – 2 OESC rule 10, 84-028 CSA C22.3 No.9 rule 7.3.2, 7.4.9 IEEE 1547 Item 4.1.2 Enova's requirement HydroOne TIR</p>
<p><b>2.3 Feeder Steady State Voltage</b></p> <p>The DG shall operate satisfactorily within the extreme voltage level variation limits of <math>\pm 6\%</math> of the nominal voltage at the Point of Connection. The generation facility shall not intentionally regulate the voltage at the Point of Connection. During normal operation and wherever possible, the generator shall be loaded or unloaded gradually to allow adequate time for regulating device to respond so as to avoid unnecessary voltage fluctuation.</p>	<p>DSC Appendix F.2 Sec. 3, 3.2 CSA CAN3-C235 Item 6.1 IEEE 1547 Item 4.1.1 HydroOne TIR</p>
<p><b>2.4 Voltage Fluctuation</b></p>	<p>DSC Appendix F.2 Sec. 3.1, 3.2</p>

Criteria	Reference																
<p>Operating the DG shall not cause a voltage fluctuation at Point of Common Coupling (PCC) to be less than 4% on connection single largest DG unit, and less than 10% when tripping all DG facilities on the connected feeder under minimum and maximum load conditions.</p>	<p>CSA C22.3 No.9 rule 7.4.14.1 HydroOne TIR</p>																
<p><b>2.5 Synchronization</b></p> <p>Paralleling or sudden tripping the DG shall not cause a voltage fluctuation of more than 4% at the Point of Connection. For synchronized generators, the interconnection with the distribution system may occur only within the synchronization limits below (from CSA C22.3 No.9):</p> <table border="1" data-bbox="155 716 1019 978"> <thead> <tr> <th>Total DG system Capacity</th> <th>Frequency Difference</th> <th>Voltage Difference</th> <th>Phase Angle Difference</th> </tr> </thead> <tbody> <tr> <td>0-500 kVA</td> <td>0.3 Hz</td> <td>10%</td> <td>20°</td> </tr> <tr> <td>&gt;500-1500 kVA</td> <td>0.2 Hz</td> <td>5%</td> <td>15°</td> </tr> <tr> <td>&gt;1500 kVA</td> <td>0.1 Hz</td> <td>3%</td> <td>10°</td> </tr> </tbody> </table> <p>For an induction generator or an inverter-based DG, the synchronization shall not create a voltage drop greater than 5% or the voltage flicker. And the induction generator should be brought close to synchronous speed prior to interconnection.</p> <p>For interconnection to Enova’s distribution system, the paralleling device shall be capable of withstanding 220% of the interconnection system rated voltage.</p>	Total DG system Capacity	Frequency Difference	Voltage Difference	Phase Angle Difference	0-500 kVA	0.3 Hz	10%	20°	>500-1500 kVA	0.2 Hz	5%	15°	>1500 kVA	0.1 Hz	3%	10°	<p>DSC Appendix F.2 Sec. 3.2, 10.6 OESC rule 84-006 CSA C22.3 No.9 rule 7.4.14, 7.4.2 IEEE 1547 Item 4.1.3, 5.1.2 HydroOne TIR</p>
Total DG system Capacity	Frequency Difference	Voltage Difference	Phase Angle Difference														
0-500 kVA	0.3 Hz	10%	20°														
>500-1500 kVA	0.2 Hz	5%	15°														
>1500 kVA	0.1 Hz	3%	10°														
<p><b>2.6 Feeder Voltage Unbalance</b></p> <p>Operation of the generation facility shall not cause objectionable voltage unbalance by more than 2% and current unbalance by 10% at the Point of Connection.</p>	<p>DSC Appendix F.2 Sec. 3.2 CSA C22.3 No.9 rule 7.2.5 HydroOne TIR</p>																
<p><b>2.7 Power Factor</b></p> <p>The generation facility shall be capable of operating within the preferred power factor range of 0.9 lagging to 0.95 leading, unless otherwise requested or approved by Enova. Under normal operating conditions, the generation facility shall maintain a power factor of 0.95 lagging or better at the PCC. The generator shall not inject reactive power (VARs) into the</p>	<p>DSC Appendix F.2 Sec. 4 CSA C22.3 No.9 rule 7.2.4.2 HydroOne TIR</p>																

Criteria	Reference
<p>distribution system unless otherwise requested or approved by Enova.</p> <p>Generation facilities 30 kW or less are not required to be capable of adjusting the power factor. Where Enova determines that the operation of a generation facility may adversely impact distribution system voltage levels at the Point of Connection, Enova may require the generator to limit the power factor range or real power output, or implement other compensatory measures (e.g., field-settable fixed or dynamic power factor control).</p>	
<p><b>2.8 Equipment Thermal Loading and Fault Interrupting rating</b></p> <p>The generation facility interface equipment shall be compatible with Enova equipment ratings and the incorporation of the added generation facility must not result in any distribution system equipment operating beyond its ratings. Enova will review the ratings of the impacted equipment in the distribution system and transformer stations under all operating conditions including but not limited to the following:</p> <ul style="list-style-type: none"> <li>- Nominal equipment thermal loading – including feeder conductor/cable, disconnect switch, fuse, station breaker/recloser and transformers etc.</li> <li>- DG fault contribution impact on the equipment rating – including disconnect switch, fuse, station breaker/recloser etc. at phase or ground fault.</li> <li>- Voltage regulating and metering device – if the generation facility causes reversed power flow at feeder level or station level, the feeder/station voltage regulation and metering device shall be capable of handling bi-directional power flow.</li> <li>- DG fault contribution impact on the feeder protection equipment – the DG fault contribution may reduce the fault current through the station breaker and cause the feeder protection malfunctioned. The feeder relay setting adjustment or relay replacement may be required.</li> </ul> <p>Enova will determine all necessary system upgrades required to accommodate the proposed generation facility. The detailed protection coordination and relay setting will be reviewed and approved at Design Review stage.</p>	<p>DSC Appendix F.2 Sec. 5 CSA C22.3 No.9 rule 7.4.2 HydroOne TIR</p>
<p><b>2.9 DG Protection – Open phase protection and Anti-Islanding</b></p>	<p>DSC Appendix F.2 Sec. 6.1.2, 6.1.3 CSA C22.3 No.9 rule 7.4.8, 7.4.12</p>

Criteria	Reference
<p>DG protections must detect the loss of any phase and disconnect the generation from the distribution system within 500ms.</p>	<p>IEEE 1547 Item 4.4.1 HydroOne TIR</p>
<p><b>2.10 Metering Devices</b></p> <p>Enova will specify the metering requirement and instrument transformer requirements.</p> <p>In general, all metering device shall be Measurement Canada Approved.</p> <p>For generation facility larger than 50kW, 4 Quadrant meter is required.</p> <p>For generation facility larger than 5MW, primary metering is required.</p> <p>The DG proponent shall incorporate the metering requirements into the system design.</p>	<p>DSC Appendix F.2 Sec. 7 HydroOne TIR</p>
<p><b>2.11 Feeder Relay Directioning</b></p> <p>The fault on the adjacent feeder may cause sympathetic tripping of the overcurrent protection on the feeder with DG connected due to the fault contribution from the DG. Inrush currents at time of generation connection to be below feeder trip levels.</p> <p>Enova will conduct the fault analysis and determine if the DG feeder relay shall be replaced with directional overcurrent relay or distance relay to detect the reverse fault current situation.</p>	<p>DSC Appendix F.2 Sec. 8 HydroOne TIR</p>
<p><b>2.12 Monitoring and Information Exchange</b></p> <p>For all generation facilities larger than 50 kW, Enova requires real-time monitoring information at Enova Control Center as summarized in the table below. The Generator shall install a communication terminal (could be SCADA master station, RTU, advanced metering, IED or equivalent) that is capable of communicating with Enova Control Center using serial DNP 3.0 protocol. The Generator is responsible to provide all the required hardware and software and make arrangements to bring all required signals to the Enova Control Center, including the communication circuit (typically a Bell circuit) between the generation facility and Enova SCADA Master Station. Other</p>	<p>DSC Appendix F.2 Sec. 9 OESC Rule 2-022 IEEE 1547 Item 4.1.6 IEEE 1547.3 CSA C22.3 No.9 rule 7.4.16 HydroOne TIR</p>

Criteria	Reference																
<p>real-time monitoring signals may be required and shall be determined by Enova.</p> <p>If Enova requires additional monitoring information for a certain generation facility, Enova will specify the requirements in the Connection Impact Assessment Report.</p> <table border="1" data-bbox="151 569 774 1167"> <thead> <tr> <th>Remote Monitoring Points</th> <th>&gt;50kW</th> </tr> </thead> <tbody> <tr> <td>Analog: total MW and MVar</td> <td>Yes</td> </tr> <tr> <td>Analog: DG 3-phase voltage</td> <td>Yes</td> </tr> <tr> <td>Analog: DG 3-phase current</td> <td>Yes</td> </tr> <tr> <td>Status: HVI/LVI Open/Close</td> <td>Yes</td> </tr> <tr> <td>Status: Transfer Trip Received</td> <td>Yes (if TT required)</td> </tr> <tr> <td>Alarm: transfer trip circuit failure</td> <td>Yes (if TT required)</td> </tr> <tr> <td>Alarm: DG interface protection failure</td> <td>Yes</td> </tr> </tbody> </table>	Remote Monitoring Points	>50kW	Analog: total MW and MVar	Yes	Analog: DG 3-phase voltage	Yes	Analog: DG 3-phase current	Yes	Status: HVI/LVI Open/Close	Yes	Status: Transfer Trip Received	Yes (if TT required)	Alarm: transfer trip circuit failure	Yes (if TT required)	Alarm: DG interface protection failure	Yes	
Remote Monitoring Points	>50kW																
Analog: total MW and MVar	Yes																
Analog: DG 3-phase voltage	Yes																
Analog: DG 3-phase current	Yes																
Status: HVI/LVI Open/Close	Yes																
Status: Transfer Trip Received	Yes (if TT required)																
Alarm: transfer trip circuit failure	Yes (if TT required)																
Alarm: DG interface protection failure	Yes																
<p><b>2.13 Direct Transfer Trip Signal from TS Feeder Breaker to DG</b></p> <p>The Customer shall make provisions to install Direct Transfer Trip (DTT) protection where the aggregate generation, including existing generation, previously proposed DG facilities, and the proposed DG facility, exceeds 50% of the minimum feeder load or the minimum load downstream of a recloser.</p> <p>Direct Transfer Trip shall also be required where the existing reclosing interval time delay (dead time) is 1.0 second or less.</p> <p>A DG End Open (DGEO) signal for auto-reclose supervision of the feeder breaker at the station shall be required where the aggregate generation exceeds 50% of the minimum feeder load, or where otherwise required by Enova.</p>	<p>Enova requirements</p> <p>HydroOne TIR</p>																

### 3. STAGE OF DESIGN REVIEW

After DG proponent accepts the Connection Impact Assessment Report and reaches the Connection Cost Agreement with Enova, Enova will conduct a detailed engineering Design Review to verify the suitability of the DG installation. The purpose of the Design Review is to confirm that all technical requirements in the CIA are met and protection coordination between the DG interface protection and the distribution feeder protection is sufficient. Enova will also review the DG commissioning plan at this stage to ensure the testing requirements. Enova may advise more technical requirements to supplement the information provided in the CIA.

#### - Document Submission Requirements for Design Review

After signing the Connection Cost Agreement, the DG proponent shall submit Enova two (2) copies of the following documents for design review:

- Single-line diagrams showing ratings of all electrical equipment, such as disconnect switches, bushing potential devices, CVTs, power transformers, grounding transformers, grounding resistors, breakers, etc. The example of single line drawing is shown in Fig. 1.
- GPR Study and associated station ground design.
- DC station service schematics showing ratings of all electrical equipment such as batteries, chargers, etc.
- Switchgear fault ratings
- HV surge arrester specification
- Transformer protection, AC and DC wiring diagrams
- Disconnect switch or HV breaker AC and DC wiring diagrams
- LV breaker (transformer & bus tie breakers) AC and DC wiring diagrams
- Breaker failure schematics (HV breaker, LV breaker)
- HV equipment operating and protection philosophy.
- Power transformer and generator nameplate ratings
- Relay settings including relay logic diagrams, coordination studies and fault calculations.
- Commissioning Procedure including the partially completed COVER form following the COVER instruction in Appendix F2: Form DG06.
- Preliminary and final generator data, including excitation system performance, automatic voltage regulator (AVR), power factor regulator, power system stabilizer, static exciter and speed governor to ensure compliance with all applicable reliability standards required under the IESO Market Rules.
- Generator absorption/deliverance of VARs from/to Enova's distribution system to maintain the voltage to a given set point.

All technical documents for submission shall be signed and sealed by a licensed Ontario

Professional Engineer. Enova may have additional requirements and will clarify when signing the Connection Cost Agreement.

### **- Design Review Criteria**

Enova will review the detailed DG protection/control system design and relay settings under various normal operating or faulty conditions and ensure the DG protection system can automatically isolate the generation facility from the distribution system when required. In general, the following interface protections will be reviewed by Enova following the Criteria in Table 3.

<b>ANSI No.</b>	<b>Description</b>
25	Synchronization check
27/59	Under/Over voltage (3 phase)
81U/O	Under/Over frequency (1 phase)
50/51	Instantaneous/Timed overcurrent
67	Directional overcurrent
21	Distance (if required)
85	Transfer trip or other anti-islanding device (if required)
DGEO	DG end open (if required)
87	Transformer differential (if equipped)
89	DG isolation device
94	Tripping relay
52BF	Breaker failure

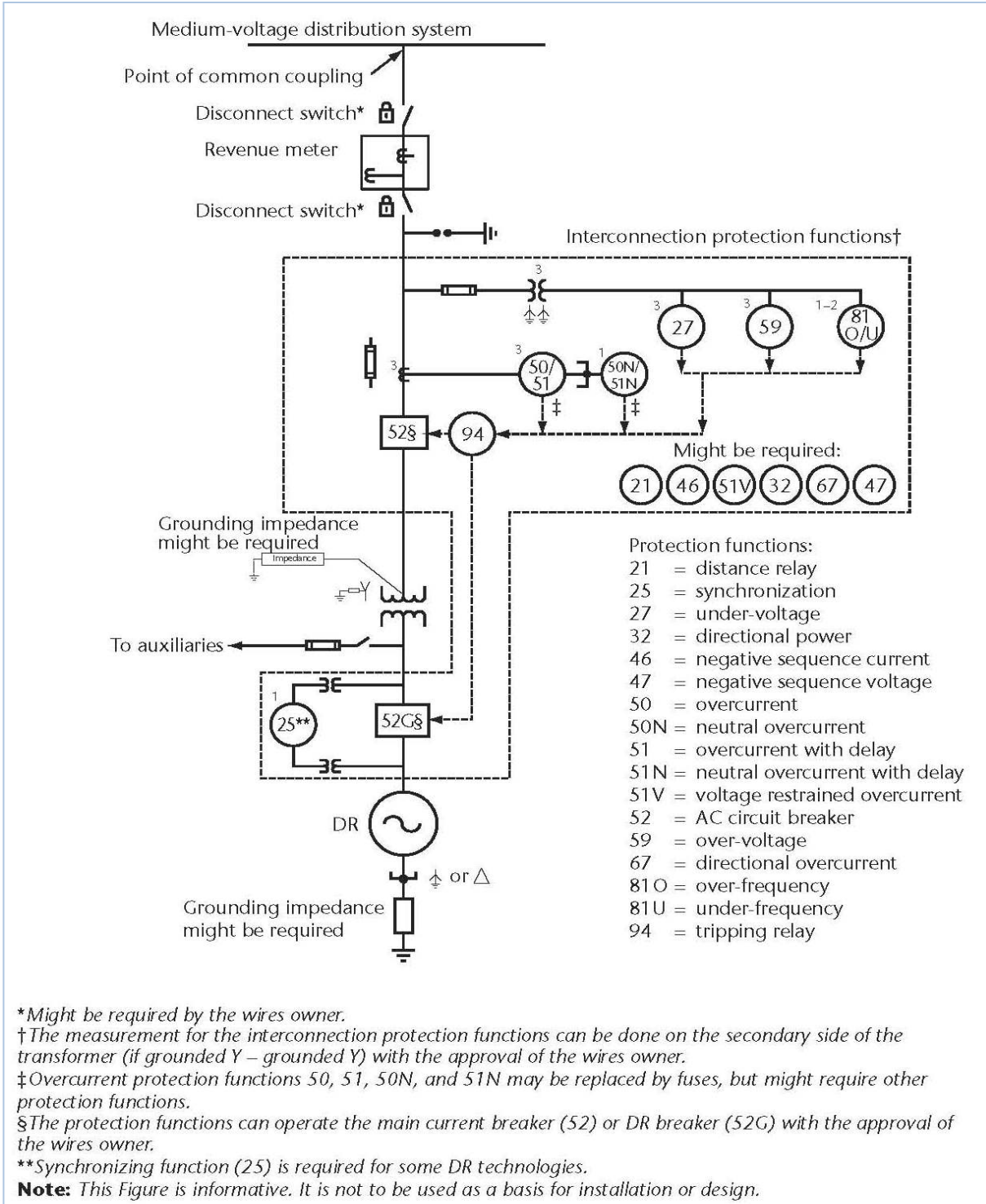

**Figure 1: Typical single line diagram (Copy of CSA C22.3 No.9)**

**Table 3: Design Review Criteria by Enova**

Criteria	Reference
<p><b>3.1 Isolation Device Verification</b></p> <p>Enova will review the isolation device design and ensure the requirements of Criteria 2.1 have been met.</p>	<p>DSC Appendix F.2 Sec. 1 OESC rule 84-026 IEEE 1547 Item 5.3.2 HydroOne TIR</p>
<p><b>3.2 Grounding Integration Verification</b></p> <p>Enova will review the DG grounding system design and ensure the requirements of Criteria 2.2 have been met.</p>	<p>OESC rule 84-026 IEEE 1547 Item 5.3.1 HydroOne TIR</p>
<p><b>3.3 DG Protection Design Verification</b></p> <p>Enova will review the DG protection/control system design under various faulty conditions and ensure the DG protection system can automatically isolate the generation facility from the distribution system at</p> <ul style="list-style-type: none"> <li>- internal faults within the generation facility; and</li> <li>-external phase / ground faults within the distribution system</li> </ul> <p>All protection devices at the generation facility shall be utility grade. The protection selectivity and sensitivity shall remain over the range of maximum and minimum system fault currents with fault contribution from the generation facility. Relay setting adjustment / relay replacement at both the generation facility and Enova’s station may be recommended.</p>	<p>OESC rule 84-014 IEEE 1547 Item 5.3.4 CSA C22.3 No.9 Item 7.4.4 HydroOne TIR</p>
<p><b>3.4 Reclosing Coordination Verification</b></p> <p>Enova will review the DG disconnection time at faults and ensure the generation facility ceases to energize prior to the auto-reclosure of Enova’s distribution feeder breaker / recloser.</p> <p>Typically, the reclosing happens 2 seconds after the feeder breaker trips in 27.6kV / 13.8kV system.</p>	<p>DSC Appendix F.2 Sec. 6 IEEE 1547 Item 5.3.4 HydroOne TIR</p>
<p><b>3.5 Over/Under Voltage Protection Verification</b></p> <p>Enova will review the settings of over/under voltage protection. The settings shall follow the requirements in IEEE 1547, as listed below:</p>	<p>DSC Appendix F.2 Sec. 6.5 IEEE 1547 Item 4.2.3 CSA C22.3 No.9 Item 7.4.7 HydroOne TIR</p>

Criteria	Reference										
<table border="1" data-bbox="164 268 997 495"> <thead> <tr> <th>Voltage @ PCC (% of the nominal 120 Base)</th> <th>Clearing time(s)</th> </tr> </thead> <tbody> <tr> <td>V &lt; 50</td> <td>0.16</td> </tr> <tr> <td>V &lt; 88</td> <td>2.00</td> </tr> <tr> <td>V &gt; 110</td> <td>1.00</td> </tr> <tr> <td>V ≥ 120</td> <td>0.16</td> </tr> </tbody> </table> <p data-bbox="155 531 1024 600">Base voltages are the nominal system voltages stated in CSA C22.3 No. 9-2020.</p>	Voltage @ PCC (% of the nominal 120 Base)	Clearing time(s)	V < 50	0.16	V < 88	2.00	V > 110	1.00	V ≥ 120	0.16	
Voltage @ PCC (% of the nominal 120 Base)	Clearing time(s)										
V < 50	0.16										
V < 88	2.00										
V > 110	1.00										
V ≥ 120	0.16										
<p data-bbox="155 659 902 695"><b>3.6 Over/Under Frequency Protection Verification</b></p> <p data-bbox="155 711 1013 816">Enova will review the settings of over/under frequency protection. The settings shall follow the requirements in IEEE 1547, as listed below:</p> <table border="1" data-bbox="175 875 1008 1066"> <thead> <tr> <th>Frequency Range (Hz)</th> <th>Clearing time(s)</th> </tr> </thead> <tbody> <tr> <td>&gt; 62.0</td> <td>0.16</td> </tr> <tr> <td>&gt; 61.2</td> <td>300</td> </tr> <tr> <td>&lt; 58.5</td> <td>300</td> </tr> <tr> <td>&lt; 56.5</td> <td>0.16</td> </tr> </tbody> </table> <p data-bbox="155 1098 1024 1167">Base voltages are the nominal system voltages stated in CSA C22.3 No. 9-2020.</p>	Frequency Range (Hz)	Clearing time(s)	> 62.0	0.16	> 61.2	300	< 58.5	300	< 56.5	0.16	<p data-bbox="1065 680 1373 894">DSC Appendix F.2 Sec. 6.5 IEEE 1547 Item 4.2.4 CSA C22.3 No.9 Item 7.4.6 HydroOne TIR</p>
Frequency Range (Hz)	Clearing time(s)										
> 62.0	0.16										
> 61.2	300										
< 58.5	300										
< 56.5	0.16										
<p data-bbox="155 1220 602 1255"><b>3.7 Reconnection Verification</b></p> <p data-bbox="155 1272 1000 1346">Enova will review the automatic reconnection settings of DG facility.</p> <p data-bbox="155 1350 1036 1528">After a disturbance on the distribution system, no reconnection shall take place until the distribution system voltage and frequency are restored within the normal limits, i.e., voltage within ±6% at the Point of Connection and frequency between 59.3 Hz and 60.5 Hz.</p> <p data-bbox="155 1533 1032 1606">The generator facility shall include a delay of at least 5minutes that delay the reconnection after the power restoration.</p>	<p data-bbox="1065 1241 1398 1419">DSC Appendix F.2 Sec. 6 CSA C22.3 No.9 Item 7.4.10, 7.4.11, 7.4.20.3 HydroOne TIR</p>										
<p data-bbox="155 1696 964 1732"><b>3.8 Monitoring and Information Exchange Verification</b></p> <p data-bbox="155 1749 1013 1854">Enova will review the DG design and ensure all monitoring and information exchange requirements in Criteria 2.12 have been incorporated into the system design.</p>	<p data-bbox="1065 1717 1373 1860">DSC Appendix F.2 Sec. 9 IEEE 1547 Item 5.3.3 HydroOne TIR</p>										

Criteria	Reference
<p><b>3.9 Anti-Islanding Protection Verification</b></p> <p>Enova will review the DG anti-islanding design and ensure all anti-islanding requirements in Criteria 2.9 have been met.</p>	<p>DSC Appendix F.2            Sec. 6.1.2, 6.1.3            CSA C22.3 No.9 rule 7.4.8, 7.4.12            IEEE 1547 Item 4.4.1            HydroOne TIR</p>
<p><b>3.10 Protection Failure Scheme Verification</b></p> <p>Enova will review the DG protection failure scheme and ensure the failure of the interface protection at the generation facility will not disrupt the distribution system.</p> <p>In case of interconnection protection failure, like breaker trip coils fail, auxiliary power is lost, the protection relay is not functional, the generation facility shall cease to energize the distribution system and isolate from the distribution system without delay.</p> <p>If the transfer trip communication function fails, the generation facility shall cease to energize the distribution system in 5 seconds.</p> <p>The affected generation facility shall not return to normal service until the protection failure is resolved and Enova is informed.</p> <p>The DG proponent shall demonstrate in the protection and control philosophy how to cease to energize the distribution system and isolate the generation facility from the distribution system in case of the protection failure.</p> <p>For generators larger than 500 kW, breaker failure protection shall be considered for HVI and LVI.</p>	<p>Enova requirements.            IEEE C37.119            CSA C22.3 No.9 rule 7.4.20,            HydroOne TIR</p>

#### 4. ADDITIONAL POWER QUALITY REQUIREMENTS AFTER DG IN SERVICE

The DG proponent shall also consider the power quality requirements listed in Table 4 when designing and testing the generation facility and ensure that the generation facility does not significantly impact the power quality. Enova will not be able to evaluate the power quality requirements at the design stage. However, if there are negative impacts on the distribution system or other customers once the generation facility is in service, the DG proponent will be required to disconnect the generation facility until the power quality issue is resolved.

**Table 4: Power Quality Criteria by Enova**

Criteria	Reference														
<p><b>4.1 Flicker</b> The generation facility shall not cause objectionable flicker for other customers serving by Enova. Indicative values of planning levels for Pst and Pit in Enova’s distribution system are shown below following IEEE 1453 (IEC 61000-4-15). The values of Pst and Pit should be measured by an approved flicker-meter in compliance with IEEE 1453 (IEC 61000-4-15).</p> <table border="1" data-bbox="321 596 808 716"> <tr> <td></td> <td><b>27.6/13.8/8.32kV</b></td> </tr> <tr> <td>Pst</td> <td>0.9</td> </tr> <tr> <td>Pit</td> <td>0.7</td> </tr> </table>		<b>27.6/13.8/8.32kV</b>	Pst	0.9	Pit	0.7	<p>DSC Appendix F.2 Sec. 10.1 IEEE 1547 Item 4.3.2 CSA C22.3 No.9 Item 7.2.2 IEEE 1453 Item 4.2.2 HydroOne TIR</p>								
	<b>27.6/13.8/8.32kV</b>														
Pst	0.9														
Pit	0.7														
<p><b>4.2 Harmonics</b> The generation facility shall not inject harmonic current such that it causes objectionable voltage distortion on the distribution system. The distortion at the Point of Connection caused by generation facility shall not exceed the limits below:</p> <table border="1" data-bbox="164 1056 1016 1314"> <thead> <tr> <th>Individual harmonic order, <math>h</math></th> <th><math>h &lt; 11</math></th> <th><math>11 \leq h &lt; 17</math></th> <th><math>17 \leq h &lt; 23</math></th> <th><math>23 \leq h &lt; 35</math></th> <th><math>35 \leq h</math></th> <th>Total demand distortion (TDD)</th> </tr> </thead> <tbody> <tr> <td>Distortion, percentage of current*†</td> <td>4.0</td> <td>2.0</td> <td>1.5</td> <td>0.6</td> <td>0.3</td> <td>5.0</td> </tr> </tbody> </table> <p>*The current specified in this Table is the greater of (a) the distribution system maximum load current integrated demand (15 or 30 min) without the DG; or (b) the DG unit rated current capacity, transformed to the PCC when a transformer exists between the DG unit and the PCC. †The maximum distortion values specified in this Table are for odd harmonics. To obtain maximum distortion values for even harmonics, the value in the corresponding <math>h</math>-range shall be multiplied by 25%.</p>	Individual harmonic order, $h$	$h < 11$	$11 \leq h < 17$	$17 \leq h < 23$	$23 \leq h < 35$	$35 \leq h$	Total demand distortion (TDD)	Distortion, percentage of current*†	4.0	2.0	1.5	0.6	0.3	5.0	<p>DSC Appendix F.2 Sec. 10.2 IEEE 1547 Item 4.3.3 CSA C22.3 No.9 Item 7.2.1 HydroOne TIR</p>
Individual harmonic order, $h$	$h < 11$	$11 \leq h < 17$	$17 \leq h < 23$	$23 \leq h < 35$	$35 \leq h$	Total demand distortion (TDD)									
Distortion, percentage of current*†	4.0	2.0	1.5	0.6	0.3	5.0									
<p><b>4.3 Limitation of DC Injection</b> The generation facility shall not inject at the point of DR connection a dc current greater than 0.5% of the generator rated output current.</p>	<p>DSC Appendix F.2 Sec. 10.3 IEEE 1547 Item 4.3.1</p>														

Criteria	Reference
	CSA C22.3 No.9 Item 7.2.7 HydroOne TIR
<p><b>4.4 Resonance and Self Excitation</b></p> <p>The generation facility shall avoid the potential effects of resonance, including</p> <ul style="list-style-type: none"> <li>(a) Ferro-resonance in the interface transformer;</li> <li>(b) Sub-synchronous resonance due to the presence of distribution capacitor banks or large rotating machines; and</li> <li>(c) Harmonic resonance with other customers when capacitors are being added as part of the installation.</li> </ul> <p>The DG proponent shall assess and address the potential resonance when designing the DG system. Enova will provide the relevant system information upon request.</p> <p>When induction generators are used, the DG proponent shall also assess and address the potential for self-excitation.</p>	CSA C22.3 No.9 Item 7.2.6 HydroOne TIR

## REQUIREMENTS FOR DG COMMISSIONING AND VERIFICATION

After DG installation is completed, the DG proponent shall perform the commissioning of the DG equipment. The commissioning process shall conform to the requirements of IEEE 1547 Section 5 and IEEE 1547.1 - Standard Conformance Test Procedures for Equipment Interconnecting Distributed Resources with Electric Power Systems. The commissioning plan shall be reviewed and approved by Enova before the commissioning.

The DG proponent shall apply for ESA electrical inspections and provide Enova the Authorization to Connect once all requirements are satisfied.

Enova will require the DG proponent complete the Confirmation of Verification and Evidence Report (COVER). The purpose of COVER is to verify the DG interface protection and control equipment meets the design requirements and the DG is ready to connect to the grids. Enova may also request site witnessing and verification during commissioning if Enova feels necessary.

## WARNING SIGNS AND DIAGRAMS

The following warning sign shall be posted on the Point of Connection, generator feeder cell and switch room door as a warning of the presence of DG:

**WARNING  
TWO POWER SOURCE  
PARALLEL SYSTEM**

A single line, permanent and legible diagram of the switching arrangement shall be placed at the generation facility's control room and the switch room to indicate the position of the

DG(s) and isolation points with the interlocking arrangements.

Operating designations will be assigned to the switching equipment of the generation system in the Connection Agreement as required by Enova. The DG customer shall update the single line electrical diagram and operating diagram to include the assigned operating designations, and the switching equipment shall be identified by the operating designations as well.